

User Manual



Implant Center 2



This document is an English translation of the original French version.
Reference J27171FR version V1 and drawing number NO20FR010A

Contents

1 Documentation	5
1.1 Associated documentation	5
1.2 Electronic documentation	5
2 Required information	7
2.1 Intended use	7
2.2 Indication for use	7
2.3 Operating principle	7
2.4 Using accessories not supplied by the manufacturer	7
2.5 Connecting and disconnecting accessories during use	7
2.6 Repairing or modifying the medical device	7
2.7 Warranty	8
2.8 Latest document update	8
2.9 Date of first CE marking	8
3 Unpacking the medical device	9
4 Connect the medical device	11
4.1 Connecting the medical device to the electrical network	11
4.2 Connecting the medical device to the electrical network	11
5 Installing the medical device	13
5.1 Fixing the medical device to a non-removable support	13
5.2 Install cords	13
5.3 Installing the control pedal	13
5.4 Connecting the handpiece	13
5.5 Connecting the motor	14
5.6 Installing an irrigation line	14
5.7 Attaching a tip or a file	15
6 Dispensing a treatment	17
6.1 Accessory usage conditions	17
6.2 Preparation for use	17
6.3 I-surge mode	18
6.3.1 Choosing a contra-angle	18
6.3.2 Select the speed of rotation	20
6.3.3 Choosing the torque	22
6.4 Piezotome mode	24
6.5 Newtron mode	25
6.6 Switching off the medical device	26
7 Medical device description	27
7.1 Control unit	27
7.1.1 Front view of the medical device	27
7.1.2 View of the right-hand side of the medical device	27
7.1.3 Rear view of the medical device	28
7.1.4 Left side view	28
7.1.5 Switch	28
7.1.6 Mains Connector	28
7.1.7 Fuse recess	28
7.1.8 Air inlets	28
7.2 Interface	28
7.2.1 Screen of the medical device	28
7.2.1.1 Piezotome mode	32
7.2.1.2 Newtron mode	33
7.2.1.3 I-surge mode	34
7.2.2 Overview of the pedal	34

7.2.2.1 Piezotome mode	35
7.2.2.2 Newtron mode	35
7.2.2.3 I-surge mode	36
7.3 Accessories	36
7.3.1 Handpiece	36
7.3.2 Handpiece support	36
7.3.3 Handpiece cord	36
7.3.4 Irrigation lines	36
7.3.5 Motor	37
7.4 Adjustments	37
7.4.1 I-Surge mode factory settings	37
7.4.2 Ultrasound power	37
7.4.2.1 Piezotome mode factory settings	37
7.4.2.2 Newtron mode factory settings	38
7.4.3 Irrigation	38
7.4.4 Adjusting the medical device volume	38
7.4.5 Adjusting the screen brightness	38
7.4.6 Adjusting the lighting timer	39
7.4.7 Recovering the medical device's factory settings	39
8 Disinfection and sterilising	41
8.1 Clean and disinfect the medical device	41
8.2 Cleaning, disinfecting and sterilising accessories	42
9 Monitoring and routine maintenance	43
9.1 Cleaning the irrigation system	43
9.2 Touch-sensitive screen messages	43
9.2.1 Problem at start up	43
9.2.2 Missing handpiece	43
9.2.3 I-Surge LED micromotor missing	44
9.2.4 Excessive motor temperature	44
9.3 Finding the software version	44
9.4 Corrective Maintenance	44
9.4.1 Replacing the fuses	44
10 Identifying incorrect operation	47
10.1 Precautions for use	47
10.2 Not working	47
10.3 The micromotor is not working	47
10.4 No spray	47
10.5 The power is not as expected	48
10.6 Ultrasounds not working	48
10.7 Water leakage	48
11 Technical specifications of the medical device	49
11.1 Identification	49
11.2 Generator	49
11.3 Length of cords	49
11.4 I-Surge LED micromotor	49
11.5 Irrigation	50
11.6 Footswitch	50
11.7 Environmental characteristics	50
11.8 Environmental restrictions	50
11.9 Main performance characteristics	51
12 Regulations and standards	53
12.1 Applicable standards and regulations	53
12.2 Medical class of the device	53

12.3 Symbols	53
12.4 Quick Start and Quick Clean symbols	55
12.5 Manufacturer identification	56
12.6 Branch addresses	56
12.7 Disposal and recycling	59
13 Index	60

1 Documentation

This document contains the following information:

- Indications for use
- Intended use
- Medical device description
- Installation of the medical device
- Medical device use
- Preparation for cleaning and disinfection of the medical device
- Monitoring and general maintenance of the medical device
- Maintenance to be performed by the user

1.1 Associated documentation

This document must be used in association with the following documents:

Document title	References
Consulting electronic user instructions	J00007
General instructions relating to the complete range of dental ultrasonic generators	J00051
Cleaning, disinfection and sterilisation instructions for keys	J81001
Cleaning, disinfection and sterilisation instructions for tips	J02001
Cleaning, disinfection and sterilisation instructions for the Handpiece-piezotome cord assembly	J12801
Cleaning, disinfection and sterilisation instructions for the I-Surge LED micromotor without lubrication	J28721
Cleaning, disinfection and sterilisation protocols for handpieces	J12911
Newtron LED handpiece user manual	J12611
Piezotome LED handpiece user manual	I12815
Ultrasonic generator power settings table	J58000
Dental surgery ultrasonic generator power settings table	J58010
Implant Center 2 user manual	J27171EN
I-Surge LED Motor user manual	J27211

The Quick Start and Quick Clean documents are summaries created for your approval. The only binding instructions are the user manuals and regulatory documentation associated with the medical device.

1.2 Electronic documentation



Electronic User
Information



Refer to
Instruction
Manual/Booklet

The user instructions for your device are available in electronic format on the specified website and not in printed format. If the website is unavailable, try again later. You can also request a free printed copy of the user instructions within seven days via our website, by telephone or in writing.

The electronic user instructions are available in PDF format (Portable Document Format). You will need to have a PDF file reader installed to read the electronic user instructions. It is important for you to have read and understood the content of the user instructions relating to the use of your device and its accessories.

Never use your device without first reading the user instructions.

The device user instructions can be consulted at www.satelec.com/documents

When you receive your device, you are asked to print and/or to download all documents or sections of documents that you may need to refer to in the event of an emergency, if you are unable to connect to the internet or if your electronic display tool is not working (computer, tablet, etc.). We recommend that you visit the website regularly to consult and to download the latest version of your device's user instructions. Users are asked to keep documentation close at hand for reference when necessary.

All paper or electronic documentation relating to your medical device must be kept for the device's entire service life.

Keep the original documentation for your medical device and its accessories for future reference. When loaning out or selling the medical device, the documentation must be provided with it.

2 Required information

2.1 Intended use

The intended use of the SATELEC Implant Center 2 is to provide utilities and to act as a base for dental instruments and accessories used by professionals qualified in dentistry.

2.2 Indication for use

The Implant Center 2 is a command unit used in combination with the following items.

An intraoral surgery ultrasonic handpiece and an intraoral surgery tip. This combination is intended for use in intraoral surgery procedures, including osteotomy osteoplasty, syndesmotomy, membrane detachment and bone expansion.

A dental ultrasonic handpiece and a dental tip. This combination is intended for use in conventional dental treatments including prophylaxis, periodontics, endodontics and conservative and restorative dentistry.

A motor handpiece, a dental contra-angle or dental straight handpiece and a rotary tool. This combination is intended for use in dentistry including restoration, endodontics and implantology procedures.

2.3 Operating principle

An electrical signal emitted by the medical device is supplied to the ultrasonic handpiece. This is connected to the medical device via a cord. The handpiece comprises a piezoelectric ceramic transducer, which transforms the electrical signal into ultrasonic vibrations.

Mechanical vibrations are transmitted to an intraoral surgery dental tip attached to the end of the ultrasonic handpiece.

The medical device must be used with a Piezotome LED handpiece. Refer to the Piezotome LED [I12815] handpiece user manual for further information.

The medical device must be used with a Newtron LED handpiece. Refer to the Newtron LED [J12611] handpiece user manual for further information.

An electrical signal emitted by the medical device is supplied to the motor. It is connected to the medical device via a cord. It consists of a rotor and stator that transform the electrical signal and mechanical rotations. The mechanical rotations are transmitted to a rotary instrument attached to the end of a contra-angle or right handpiece.

Refer to the I-Surge LED micromotor [J27211] user manual for further information.

2.4 Using accessories not supplied by the manufacturer

The handpiece is designed to operate with SATELEC, a company of Acteon group tips. The use of other makes of tips will damage the handpiece and break the tips.

2.5 Connecting and disconnecting accessories during use

Do not tighten or loosen the tips when the handpiece is activated.

Do not connect/disconnect the cords when the medical device is switched ON and the footswitch is pressed.

Do not screw or unscrew the rotary instruments when the motor is activated.

2.6 Repairing or modifying the medical device

Contact the supplier of your device. Using the services of an unapproved repairer could render your device dangerous for you and your patients.

Do not repair or modify the device without seeking the prior permission of SATELEC, a company of Acteon group.

If the device is modified or repaired, specific checks and tests must be carried out to ensure that the medical device is still safe to use.

In the event of doubt, contact an approved dealer or the SATELEC, a company of Acteon group Customer Service team:

www.acteongroup.com

satelec@acteongroup.com

SATELEC, a company of Acteon group, at the request of technical personnel working for the network of approved dealers, will provide any information required to repair defective parts on which they may perform repairs.

2.7 Warranty

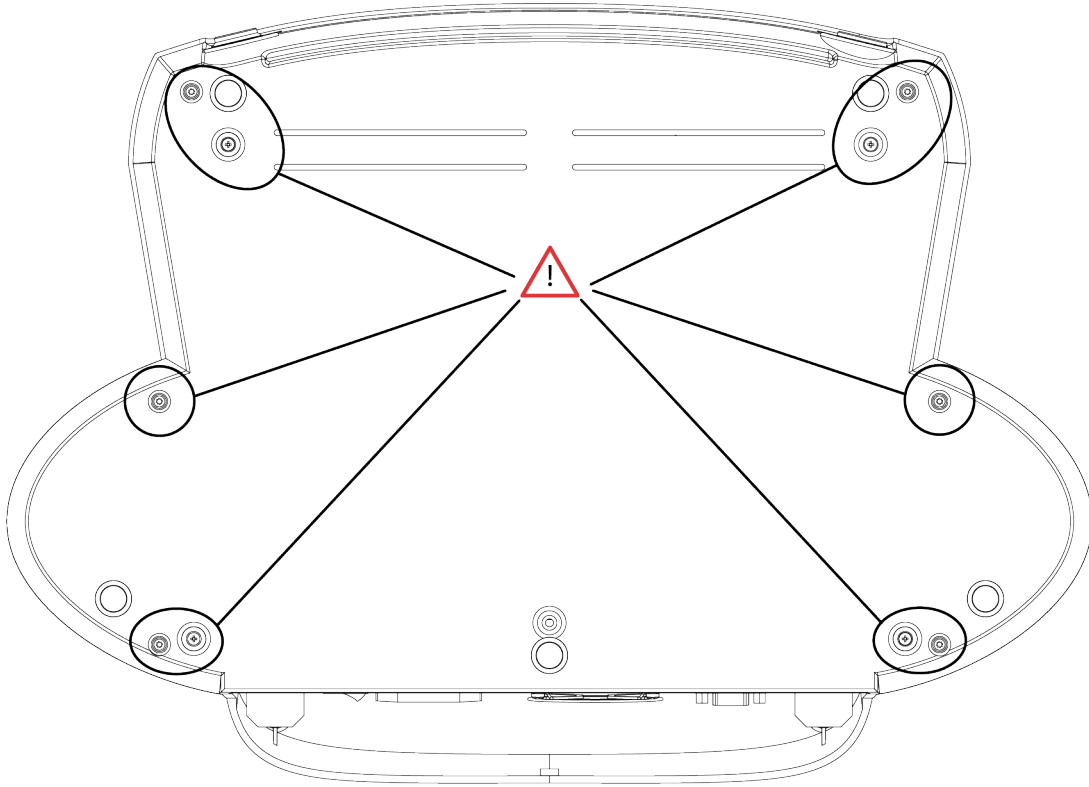

The user must not remove any of the screws shown in this view or risk invalidating the medical device's warranty.

2.8 Latest document update

04/2022

2.9 Date of first CE marking

2010

3 Unpacking the medical device

When you receive your medical device, check for any damage that may have occurred during transportation. If you have received this medical device by mistake, please contact the supplier to arrange for it to be collected. If you have any questions or requirements, contact your supplier.

The Implant Center 2 includes the following items:

- A Implant Center 2 unit
- A footswitch with its non-detachable cord
- Two handpiece supports
- A Implant Center 2 [I27161] Quick Start guide.
- A I-Surge LED micromotor with its detachable cord
- A Quick Clean guide for the I-Surge LED micromotor [J27211]
- Two autoclavable irrigation lines
- Plastic clips for the irrigation line
- An attachment kit.
- Tips and wrenches depending on selected options.
- A power cord
- Two brackets to hold the irrigation solutions

4 Connect the medical device

4.1 Connecting the medical device to the electrical network

| Have your medical device connected to the mains power by an approved dental installation technician.

Check that the mains voltage is compatible with that indicated on the medical device or its mains cord.

A different voltage would cause damage to the medical device and could injure the patient and the user. Any variation in the electrical network voltage or electromagnetic field that is non-compliant with the limits in force, could interfere with the medical device's operation.

Medical devices equipped with a protective earth must be connected to a supply network equipped with a protective earth.

| Do not plug the medical device into an extension lead and do not put the mains cord in a cable cover or cable tray.

| If when using the medical device, a power outage can create an unacceptable risk, the user and the installer must ensure that the medical device is connected to an appropriate power source such as an uninterruptable power supply.

4.2 Connecting the medical device to the electrical network

1. Set the medical device's mains switch to "O" OFF position.
2. Connect the mains cord to the control unit's mains connector.
3. Connect the power lead to the mains socket.

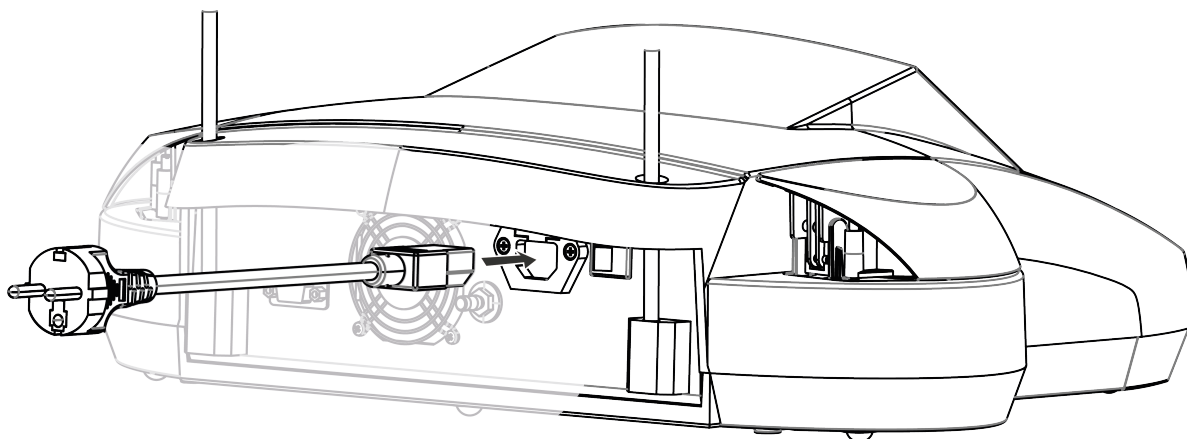

5 Installing the medical device

Place the medical device in the position that is suitable for your activity.

The medical device must be placed on a secure and flat surface or a surface with a maximum slope of five degrees.

Check that the cords do not hinder the movement or free circulation of anyone.

Adjust the position of your medical device to correspond to your angle of vision and the characteristics of your workstation, e.g. lighting or distance between the user and the medical device.

Ensure that your mains power disconnecting device is readily accessible. The mains power disconnecting devices - the switch and the power plug - must be easy to access.

Do not install your medical device near or on another device.

5.1 Fixing the medical device to a non-removable support

After its initial installation, the medical device is not designed to be moved. The medical device must be fixed to ensure that it cannot be removed or moved without the use of a tool.

5.2 Install cords

Never wrap the handpiece cord around the medical device.

Make sure that it is not possible to wheel over or walk on the different cords.

The cord attached to its handpiece must be easily accessible. Make sure that the cord is slack during use.

Likewise, the cord attached to its I-Surge LED micromotor must be easily accessible. Make sure that the cord is slack when using this device.

5.3 Installing the control pedal

Connect the footswitch cord to the back of the medical device.

The control pedal must be positioned near the feet of the operator and must be readily accessible.

5.4 Connecting the handpiece

Connect the cord and handpiece assembly to the connector on the control unit panel.

The connector bears the ultrasound symbol:



Align the mark on the cord connector with the mark on the plug. Insert the connector until you hear a click.

The Implant Center 2 enables the connection of either an intraoral dental surgery handpiece or a dental handpiece.

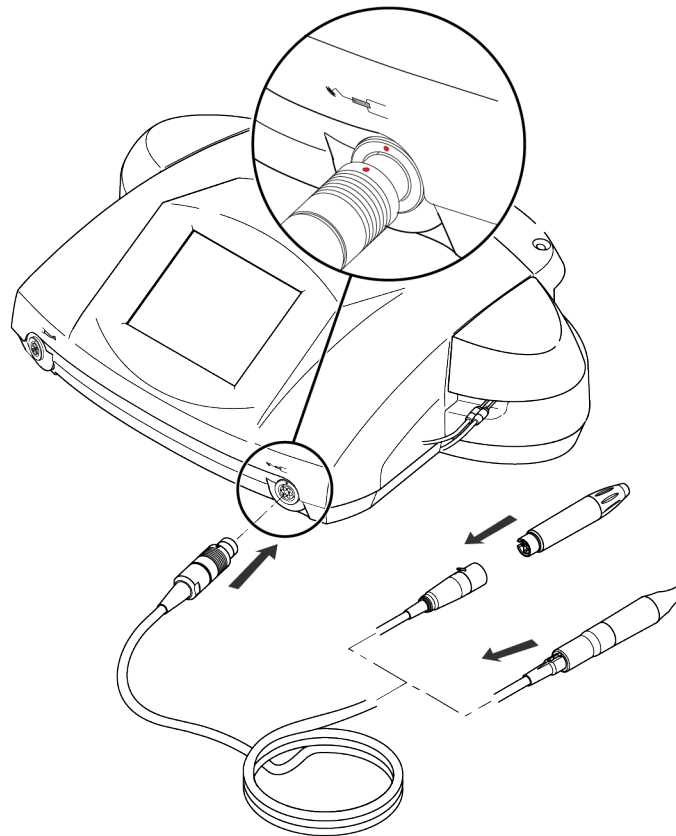

5.5 Connecting the motor

Connect the motor to the cord, then connect the motor and cord assembly to the connector on the front panel.

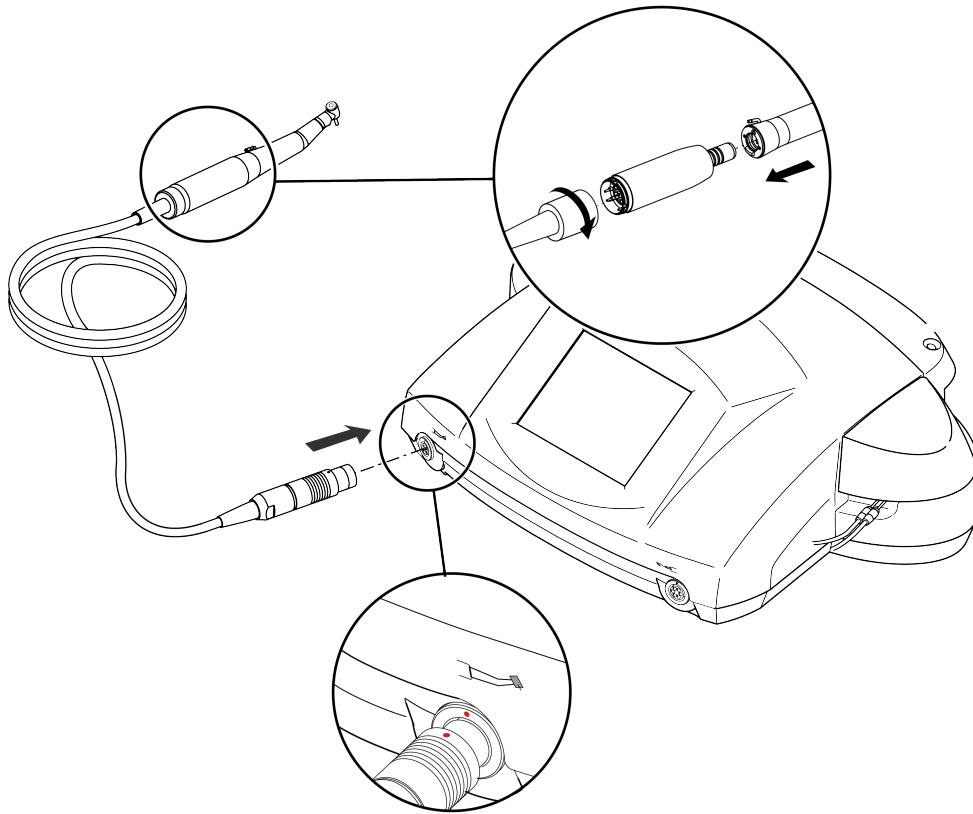

5.6 Installing an irrigation line

1. Insert the bracket into its holder.
2. Remove the irrigation line from its sterilisation bag.
3. Remove the clips from their bag.
4. Open the cassette holder on the right side of the medical device.
5. Insert the cassette and close the holder.
6. Connect the end of the irrigation line, the long infusion line, to the handpiece
7. Working your hands along the handpiece cord, attach the irrigation line to the handpiece cord using the clips. Any excess irrigation line will be at the medical device unit and will not hamper use of the handpiece.
8. Install a solution bag on the bracket
9. On the short infusion line side, pierce the irrigation solution bag with the perforator.
10. When the medical device is switched ON, open the perforator cap and purge the irrigation system.

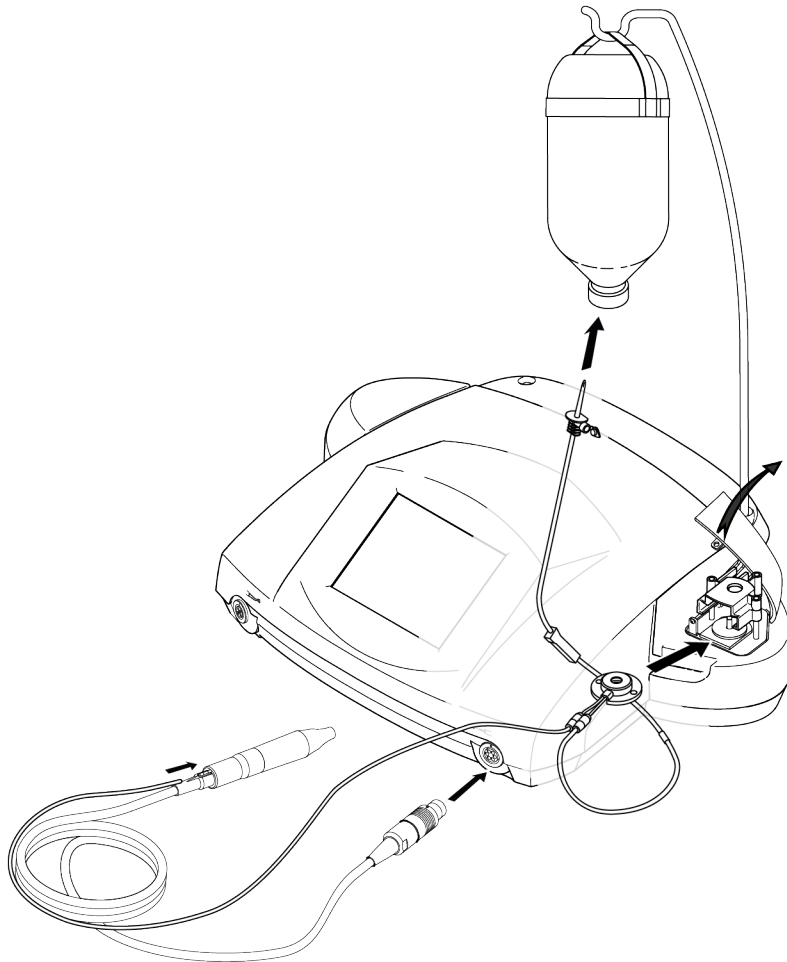

5.7 Attaching a tip or a file

The tips that can be used on this medical device are referred to as "second generation". They are recognizable by the engraving II on the base. They are incompatible with first-generation Implant Center and Piezotome tips. Conversely, older-generation tips are incompatible with Piezotome Cube, Implant Center Cube, Implant Center 2, and Piezotome Solo LED.

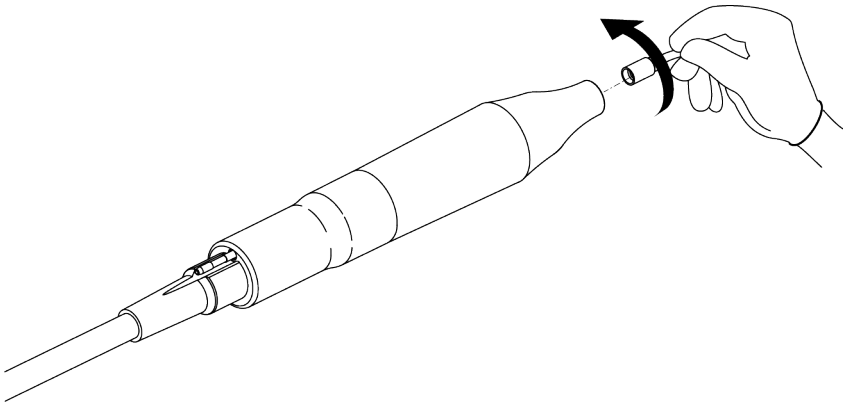

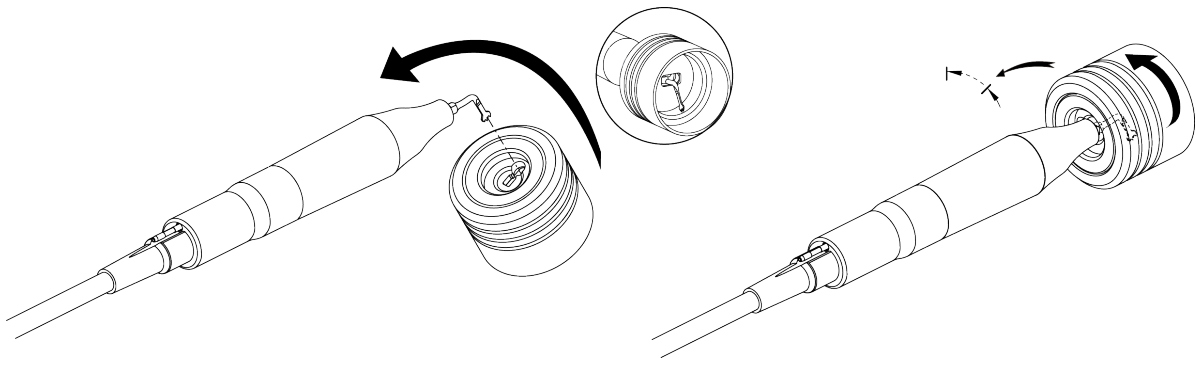

6 Dispensing a treatment

6.1 Accessory usage conditions

The accessories of the Implant Center 2 must be cleaned, disinfected and sterilised prior to each use.

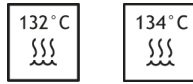

Refer to the cleaning, disinfection and sterilisation protocols for accessories listed in the chapter *Associated documentation page 5*.

This medical device is designed to be used in conjunction with a SATELEC, a company of Acteon group handpiece and second-generation intraoral dental surgery tips.

6.2 Preparation for use

To prepare your medical device, follow the steps below:

1. Wear safety goggles and protective gloves.
2. Put the handpiece support in place.
3. Clean the unit with an alcohol disinfectant wipe.



Protection
Glasses Needed

1. Put the bracket in place.
2. Connect the handpiece cord to the connector on the front of the medical device.
3. Remove the handpiece support from its sterilisation pouch.
4. Remove the handpiece and its cord out of its sterilisation pouch.
5. Remove the wrench from its sterilisation bag.
6. Remove the tip from its sterilisation bag.
7. Screw the tip onto the handpiece, first manually and finishing with the wrench.
8. Place the handpiece on its support.
9. Put an irrigation solution bag in place on the bracket.
10. Remove the irrigation line and its cassette from its sterilisation bag or packaging if sterile.
11. Put in place the irrigation line and its cassette, up to the irrigation bag.
12. Switch on the medical device.
13. Check the mode according to the chosen tip and adjust the active mode via the touch zones



14. , and .
15. Check the irrigation settings according to the chosen tip and adjust the flow via the touch zones.



and .



16. Adjust the ultrasound power using the keys and .
17. Above a water drain, check that the spray of the handpiece is working properly.

Do the same for setting up the irrigation line for the micromotor, steps 1 to 13.

Your medical device is now ready to use.

6.3 I-surge mode

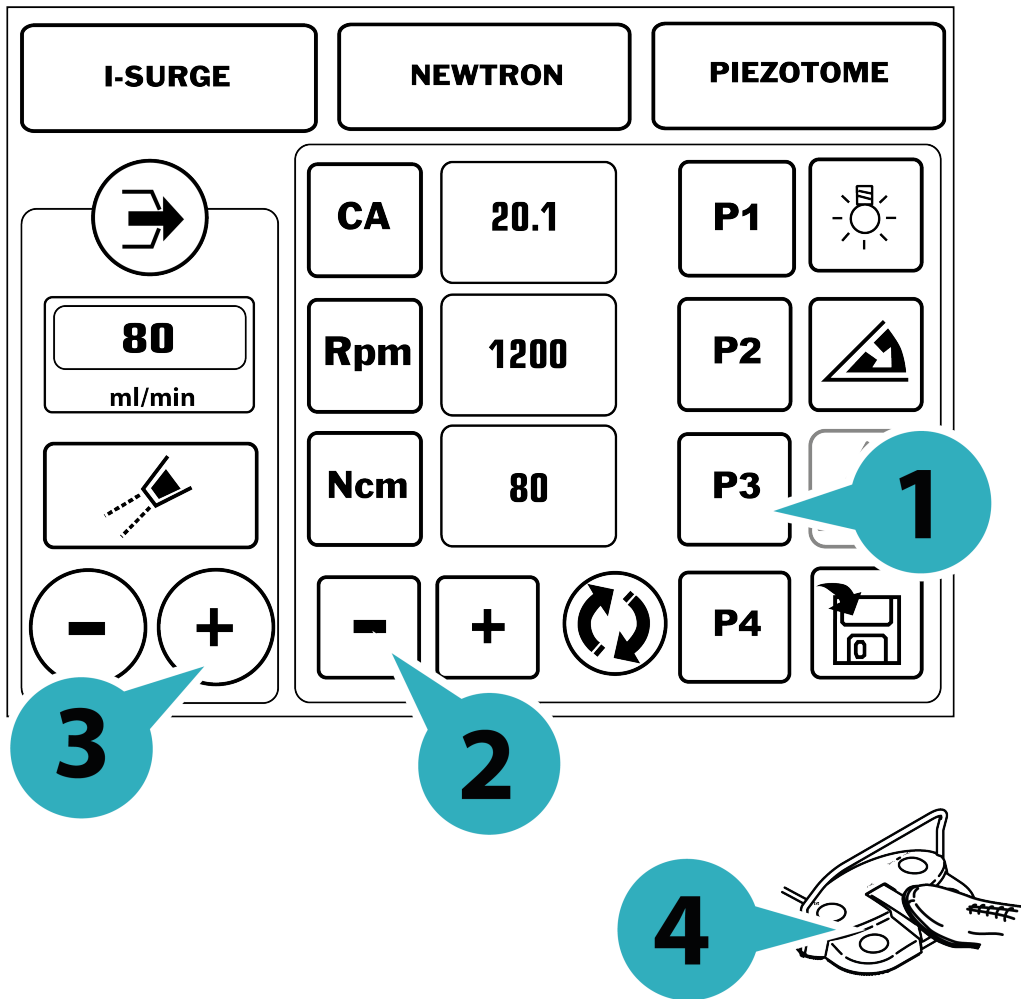

6.3.1 Choosing a contra-angle

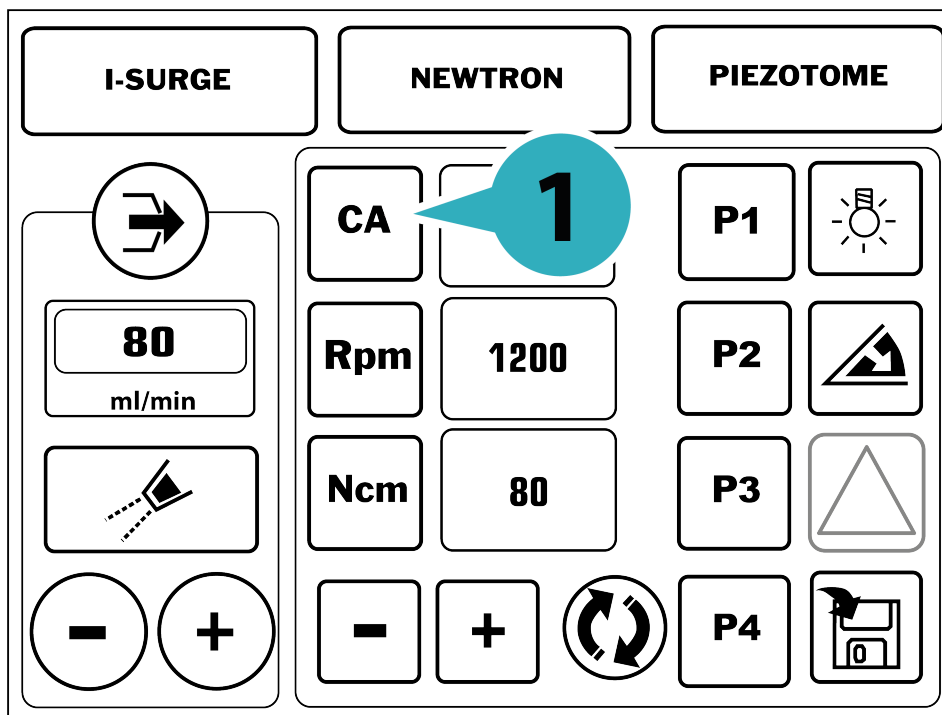

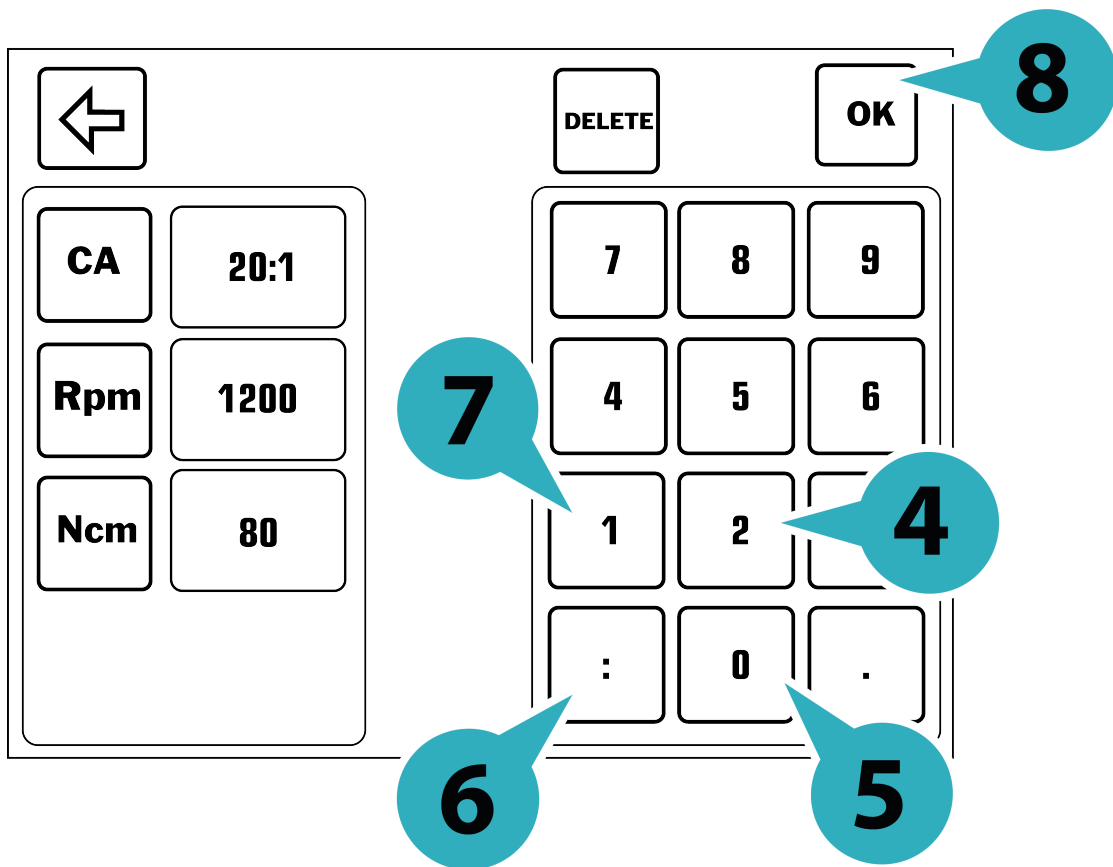
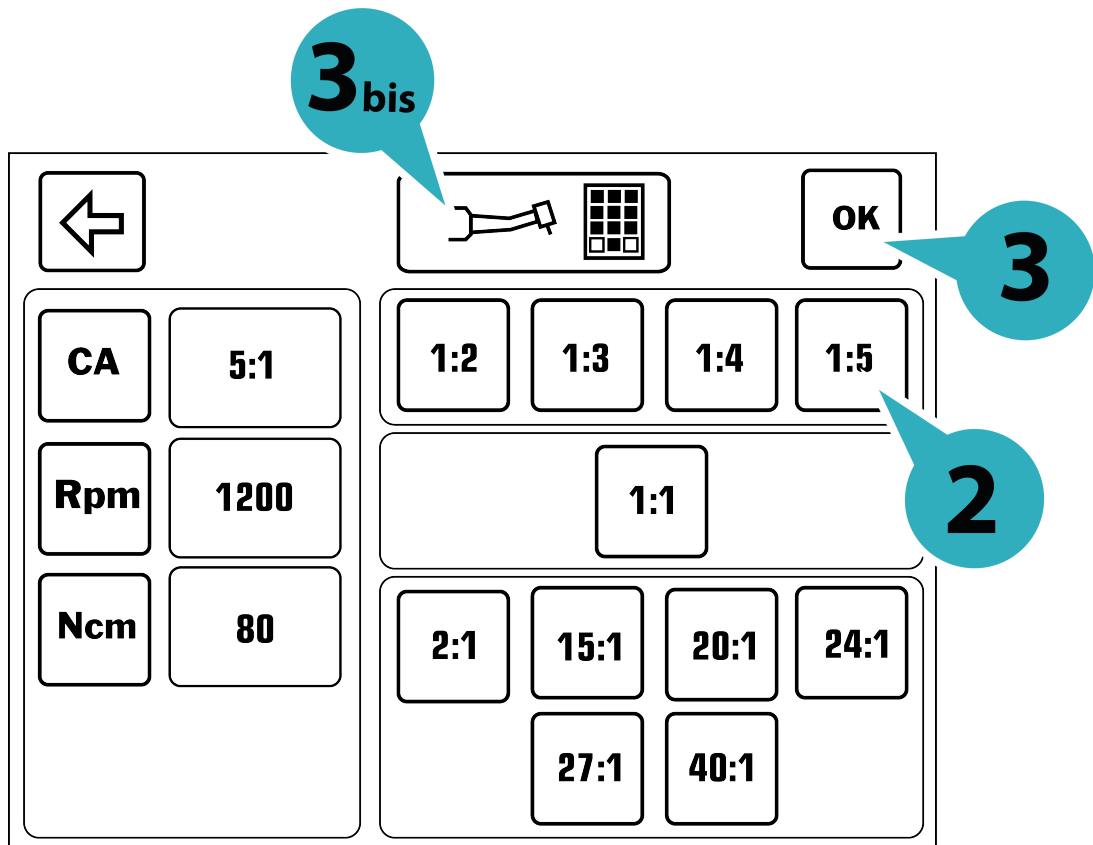

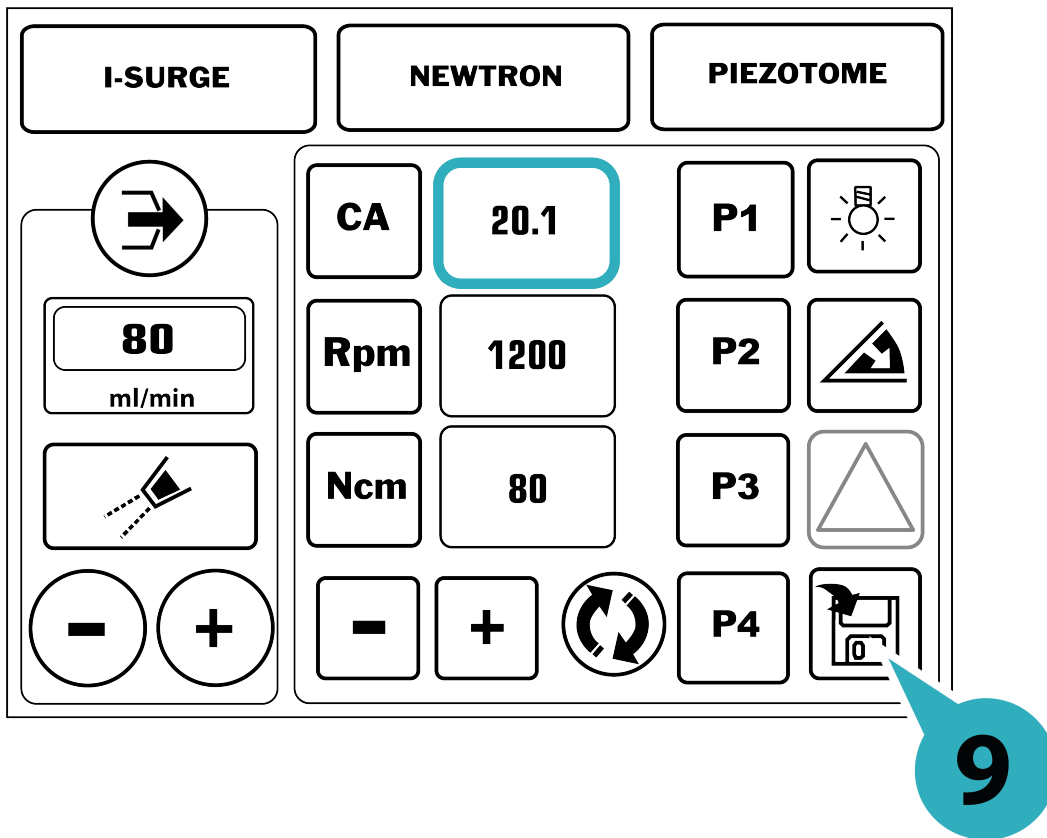

6.3.2 Select the speed of rotation

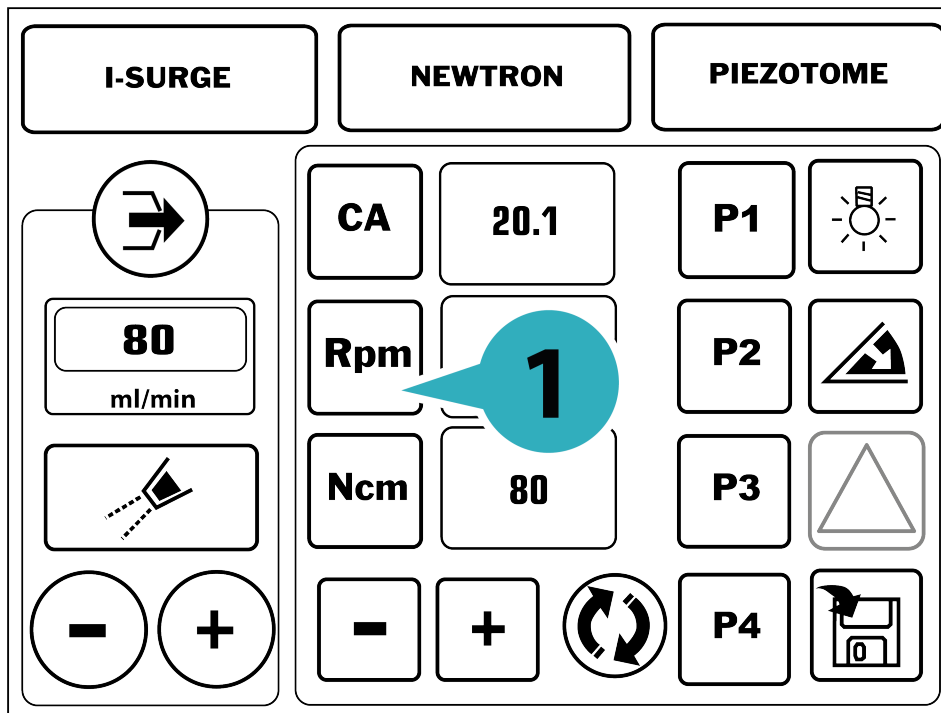

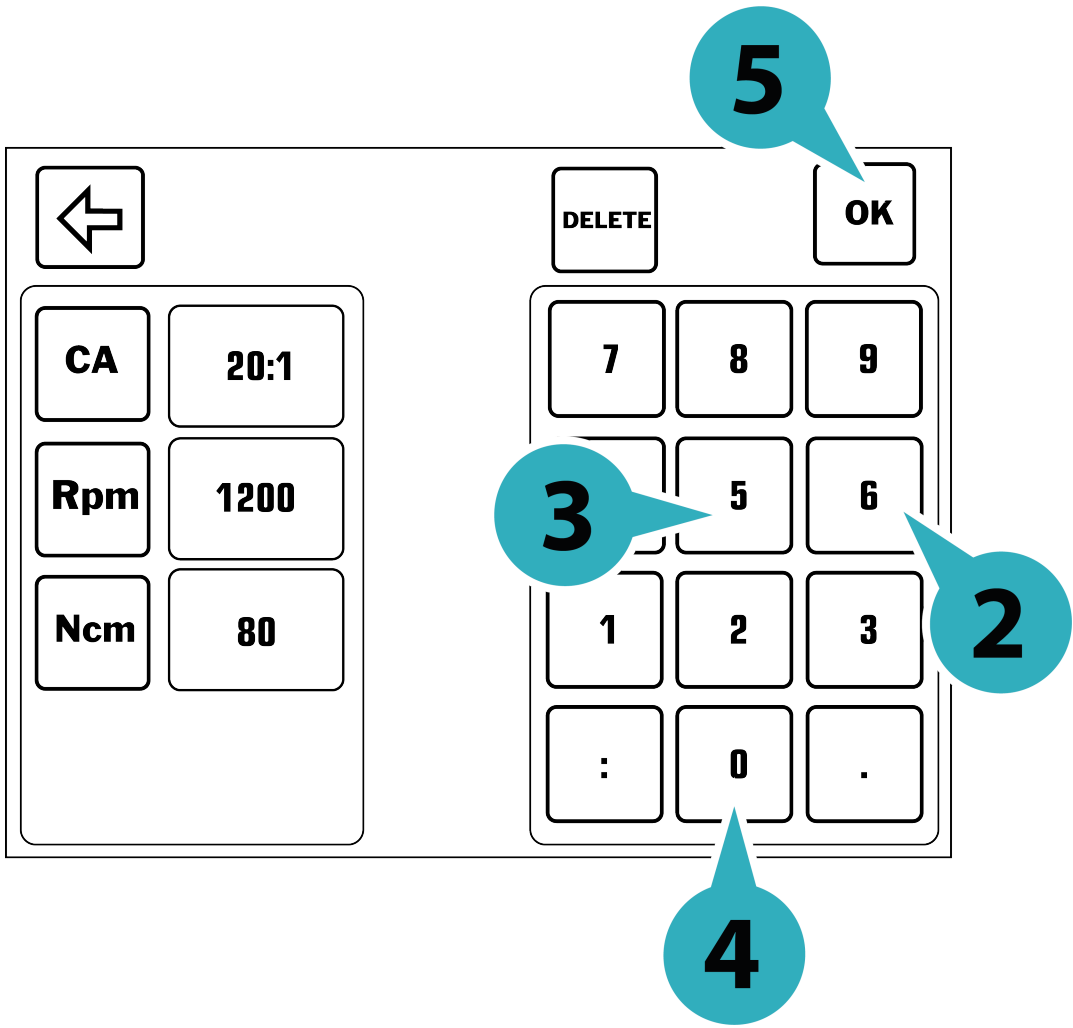

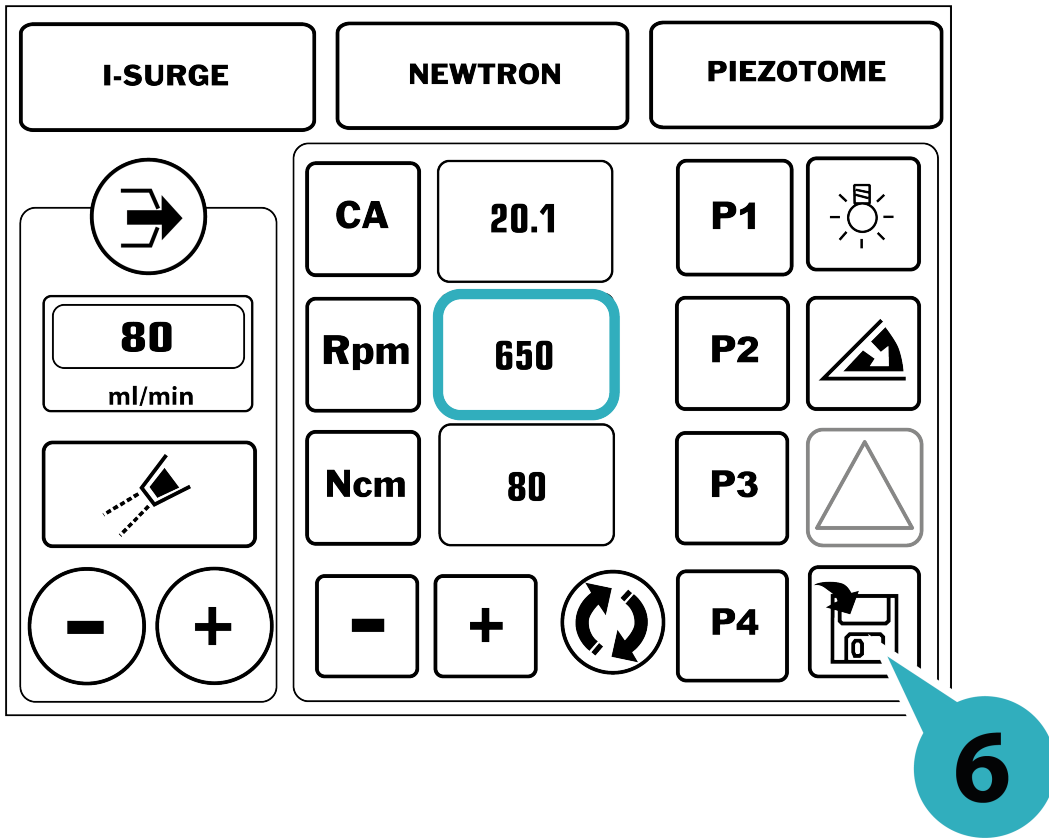

6.3.3 Choosing the torque

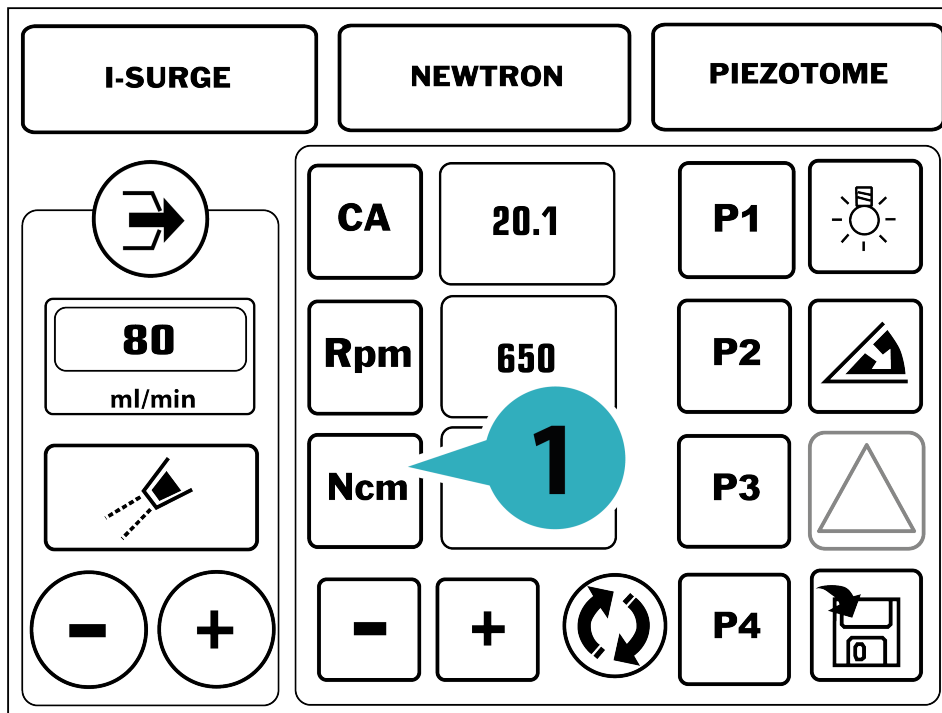

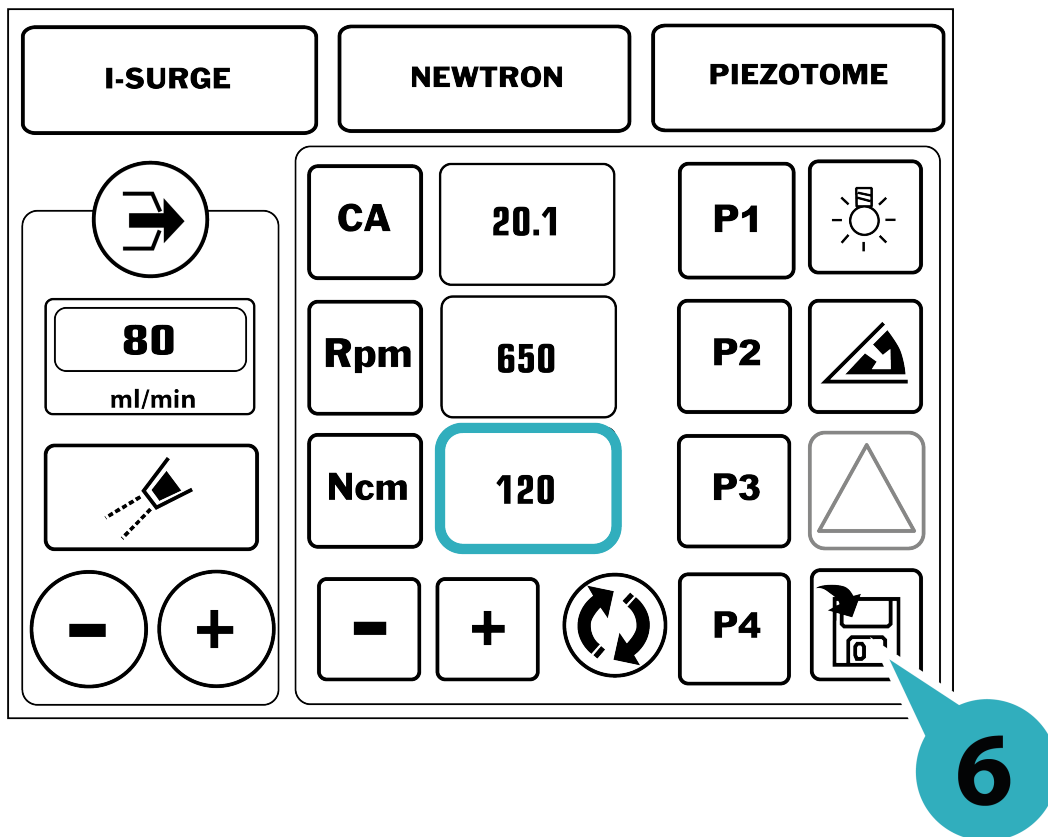
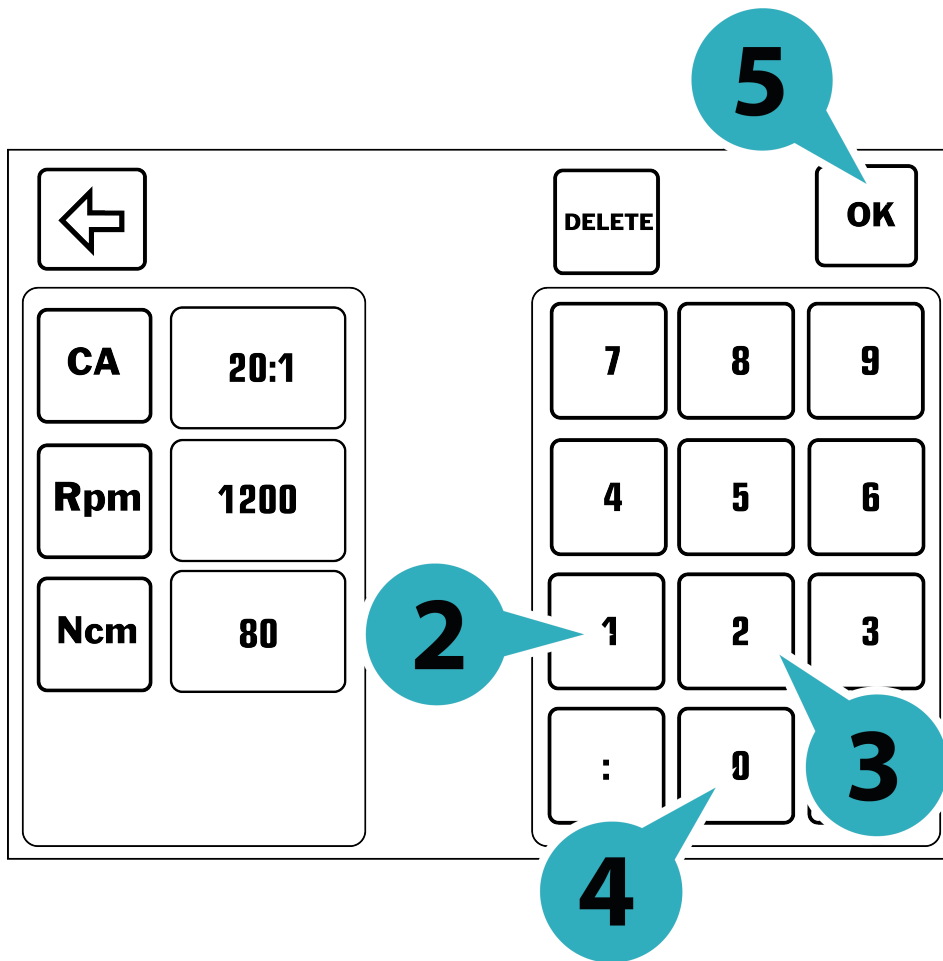

6.4 Piezotome mode

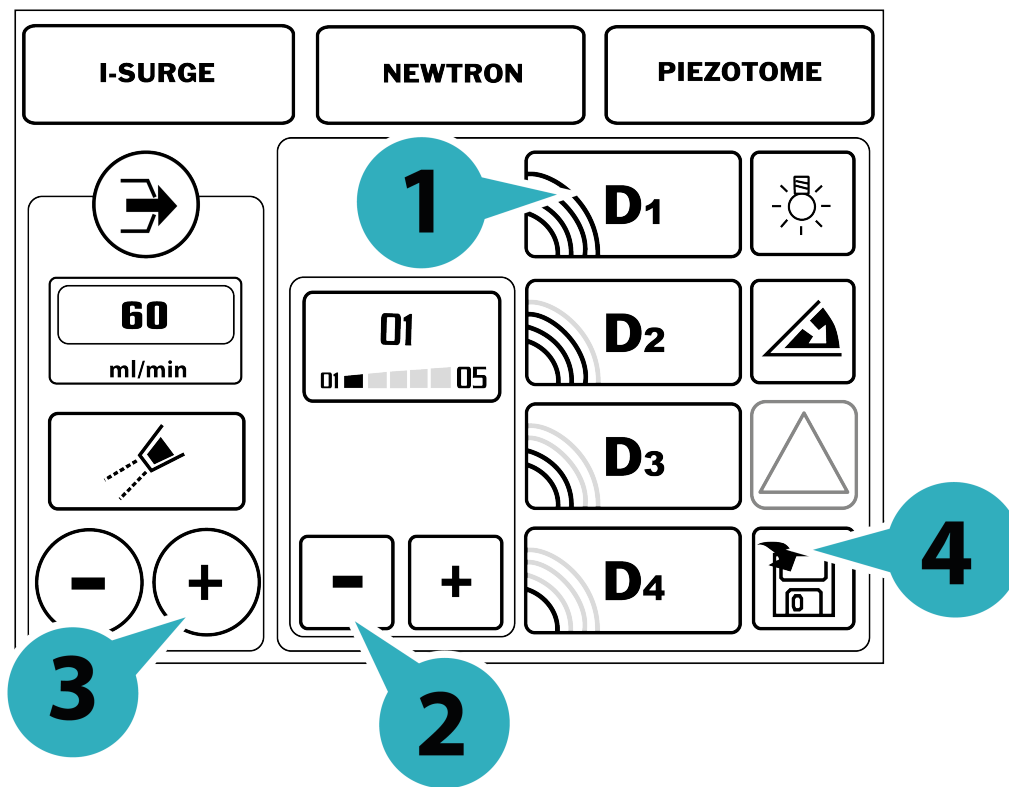
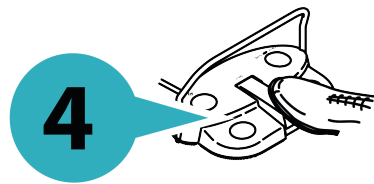
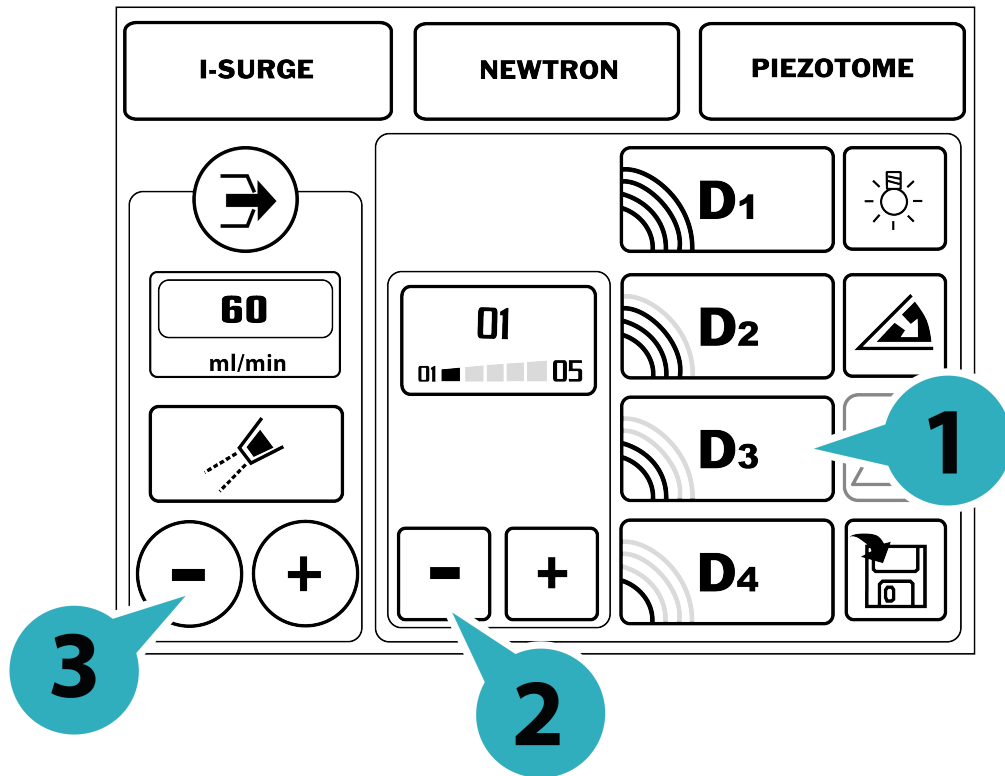

6.5 Newtron mode

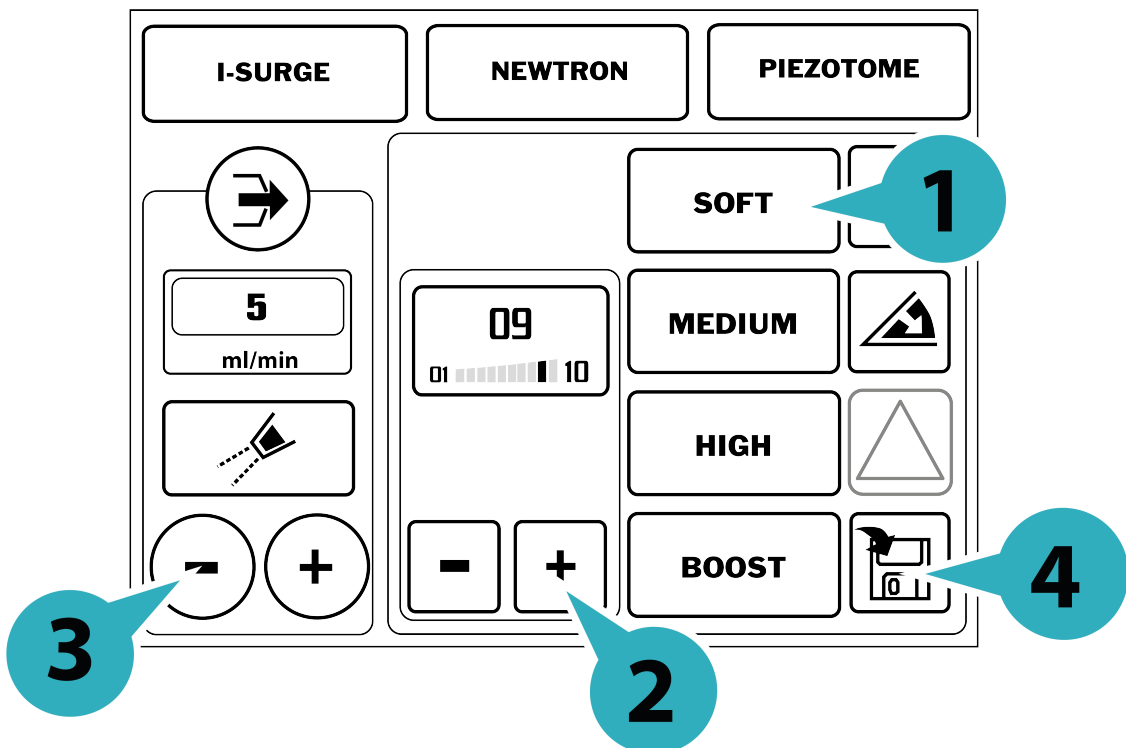
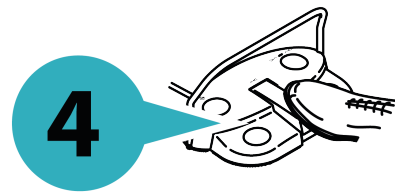
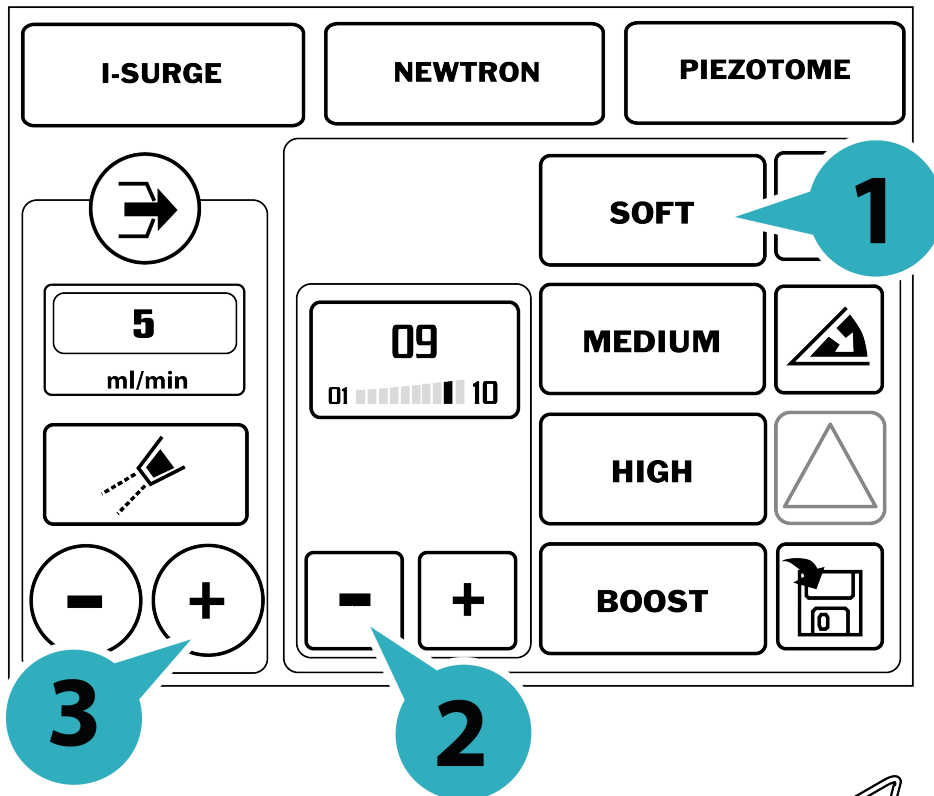

6.6 Switching off the medical device

After installation and before first use, at the end of the day and following a period of prolonged non-use of the medical device, it is important to clean the irrigation system.

This allows the autoclavable irrigation line to be cleaned prior to being disinfected, cleaned and sterilised.

When using irrigation solution bags to irrigate your medical device:

1. Disconnect the irrigation bag from the perforator of the irrigation line.
2. Dispose of the irrigation bag.
3. Dip the short end of the irrigation line in a recipient containing a hypochlorite solution diluted at less than 3%.



4. Press the Purge icon . The purge flow rate is 120 ml/min.
5. Operate the irrigation spray for two minutes to rinse the medical device's internal water system.
6. Refill the tank with demineralised or distilled water.
7. Rinse the irrigation system for two minutes.

When the irrigation system has been cleaned, perform the following operations:

1. Disconnect the handpiece and cord assembly and refer to the cleaning, disinfection and sterilisation protocols for the handpiece assembly [J12911] and [J12801], and the protocol for the micromotor [J28721].
2. Clean and disinfect the medical device as indicated in the chapter *Clean and disinfect the medical device page 41*.
3. Follow the instructions of protocols for cleaning, disinfecting and sterilising SATELEC, a company of Acteon group accessories [J81001] and [J02001].

To avoid damaging the I-Surge LED micromotor, it must be rinsed with sterile water within 30 minutes of the end of use.

1. Remove the bag from the bracket.
2. Remove the irrigation line perforator from the bag.
3. Immerse the irrigation line perforator in a container with distilled water.
4. Press the purge button for one minute to rinse the micromotor, contra-angle or straight handpiece.
5. Remove the perforator from the container and purge the system until the medical device's irrigation line is completely empty.
6. Switch off the medical device (O/I switch to O).
7. Disconnect the I-Surge LED micromotor cord from the medical device.
8. Remove the irrigation line clips and clean them with the disinfecting alcoholic wipe.
9. Disconnect the irrigation line from the I-Surge LED micromotor and dispose of it in a biomedical waste container.
10. Disconnect the contra-angle or straight handpiece from the I-Surge LED micromotor and apply the appropriate pre-disinfection, cleaning and sterilisation protocol.
11. Rinse the micromotor and apply the appropriate pre-disinfection, cleaning and sterilisation protocol.

Refer to the cleaning and sterilisation protocols for I-Surge LED micromotors, handpieces and tips for further information about the detailed sequence of pre-disinfection, cleaning and sterilisation operations for these medical devices.

When not in use, or in storage or before a long absence, disconnect the medical device from the mains power supply.

7 Medical device description

7.1 Control unit

The control unit incorporates Newtron® technology patented by SATELEC, a company of Acteon group .

Newtron® technology emits ultrasonic vibrations in a controlled way. These vibrations, relayed by SATELEC, a company of Acteon group tips, are used to deliver effective treatments and to ensure patient safety.

The control unit incorporates an dental ultrasonic generator equipped with a piezoelectric command.

The control unit incorporates electronic control elements to drive a brushless sensorless motor.

7.1.1 Front view of the medical device

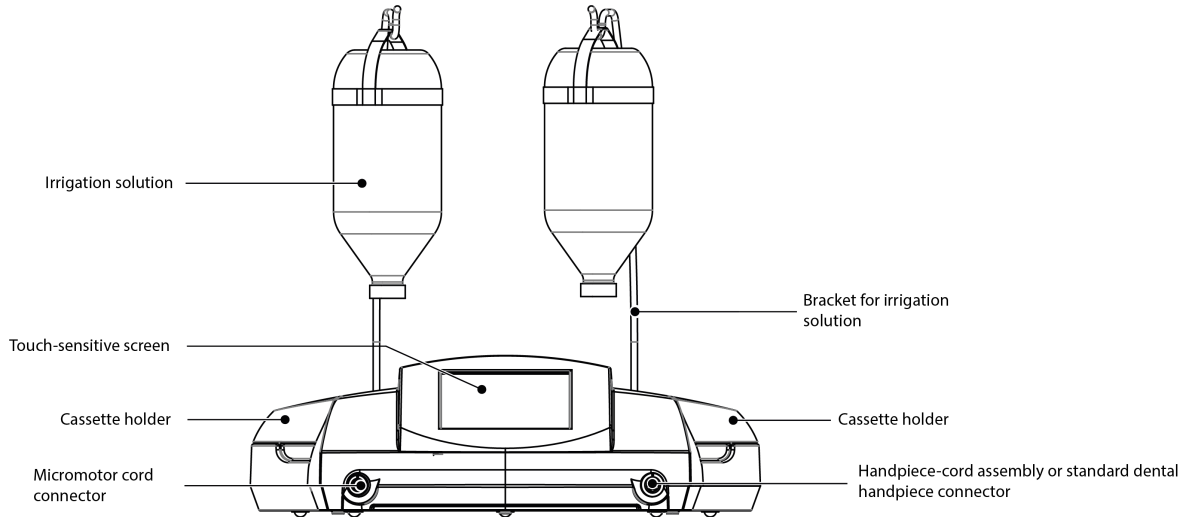

7.1.2 View of the right-hand side of the medical device

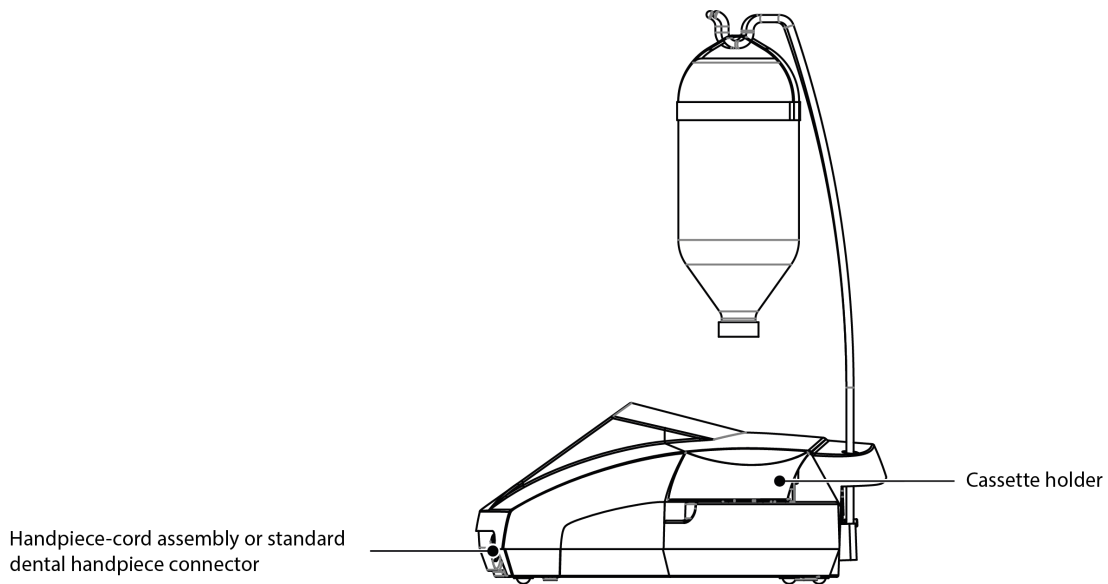

7.1.3 Rear view of the medical device

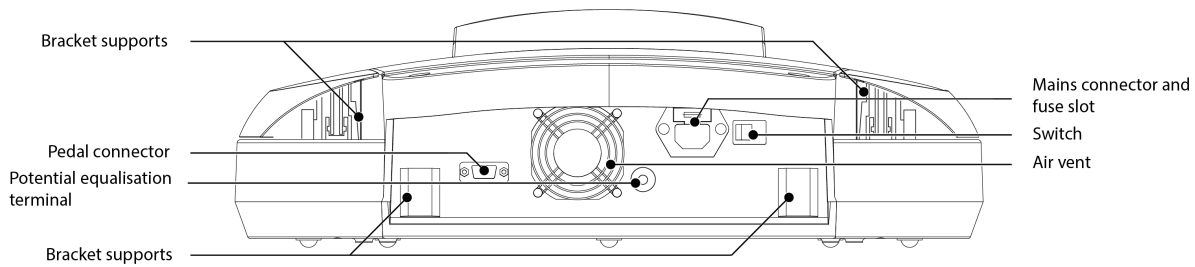

7.1.4 Left side view

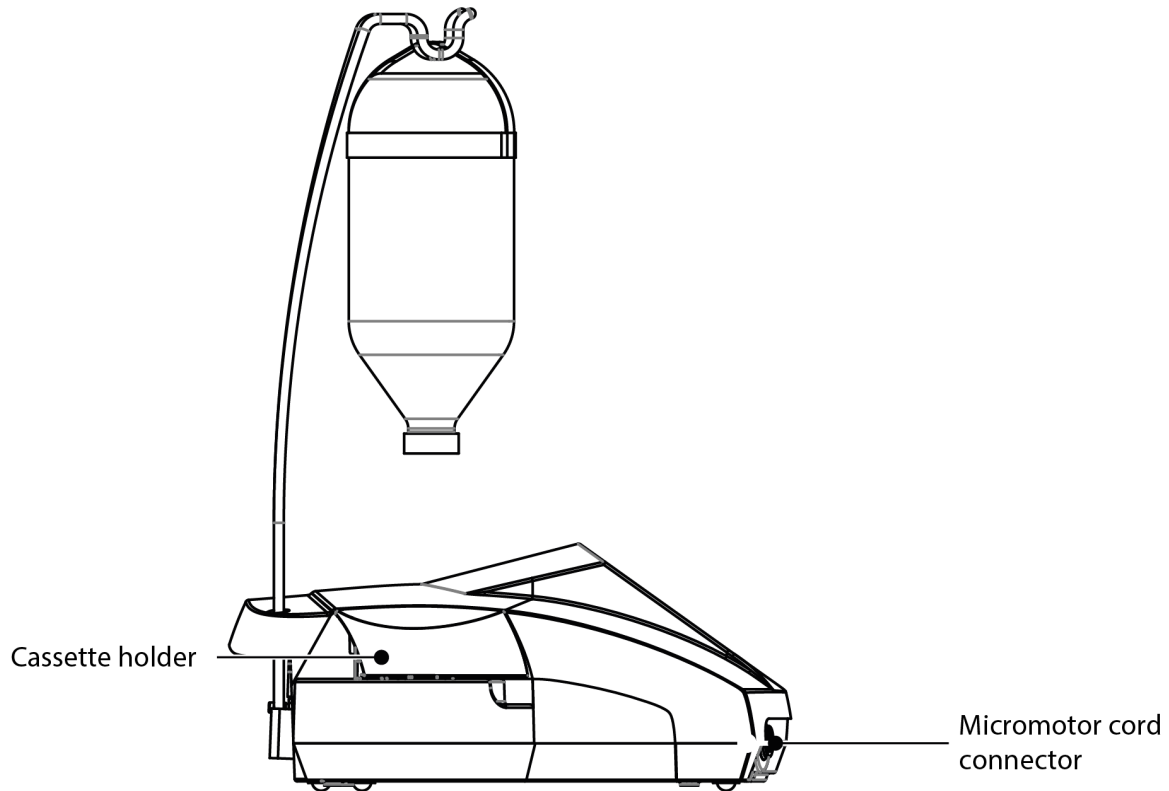

7.1.5 Switch

The mains switch is used to switch on (position I) or to stop (position O) the medical device.

7.1.6 Mains Connector

The mains connector with its earthing pin is used to connect the device to the electrical network via a disconnectable mains cord.

7.1.7 Fuse recess

The recess holds two fuses designed to protect the medical device in the event of overvoltage or an internal fault. Please read the instructions listed in the chapter *Replacing the fuses* page 44

7.1.8 Air inlets

Air inlets ensure correct ventilation of the control unit. Leave them uncovered to allow air to circulate.

7.2 Interface



7.2.1 Screen of the medical device

The screen of the medical device serves as the interface display. It is tactile such that practitioners can make adjustments by pressing the active areas.











▮ Always make adjustments with your finger. Never use stylets or instruments, as these may damage the screen.









The touch zones are capacitive and extremely sensitive. The screen must therefore be constantly clean and dry to avoid disturbing user-defined settings.





The medical device can be used in any of the following modes:



-  I-Surge: with I-Surge LED micromotor and contra-angles or a straight handpiece
-  Piezotome: with Piezotome LED handpiece
-  Newtron: with Newtron LED handpiece.











Switch between modes by pressing the pictograms or using the footswitch.

Pictograms shared by both modes	Meaning
	Start/stop purge
	Displays the flow in ml/min
	Irrigation ON
	Irrigation OFF
	Adjusts the irrigation flow rate
	Handpiece lighting on
	Handpiece lighting off
	Progressive footswitch
	Smooth footswitch
	Warning. The type of warning is specified by a pictogram at the centre of the triangle.
	Save any changes made to programmes

Pictograms for the Piezotome mode	Meaning	Power
	Select programme D1 - Osteotomy, osteoplasty	Very powerful
	Select programme D2 - Osteotomy, osteoplasty	Powerful
	Select programme D3 - Osteotomy, osteoplasty	Average power
	Select programme D4 - Detachment of soft tissue	Low power
	Used power per programme - press the + and - pictograms to adjust the value	
	Adjust the power	
	Progressive footswitch:	
	Smooth footswitch	

Pictograms for the Neutron mode	Meaning	Power
	Soft programme	Low
	Medium programme	Medium
	High programme	High
	Boost programme	Very high

Pictograms for the Newton mode	Meaning	Power
	Used power per programme - press the + and - pictograms to adjust the value	
	Adjust the power	

Pictograms for the I-Surge mode	Meaning
	Current contra-angle - press the pictogram to select a different contra-angle or personalise a specific contra-angle
	Revolutions per minute- adjust this value using the + and - pictograms on the screen
	Newton-centimetre - press the pictogram to adjust the torque of the force applied at the outlet of the contra-angle
	In P1, P2 and P3, directly adjust the number of revolutions per minute. In P4, adjust the torque in real time.
	Select programme P1 - Marking of the implant site
	Select programme P2 - Pilot drilling
	Select programme P3 - Boring/threading
	Select programme P4 - Screwing
	Clockwise rotation
	Anti-clockwise rotation

7.2.1.1 Piezotome mode

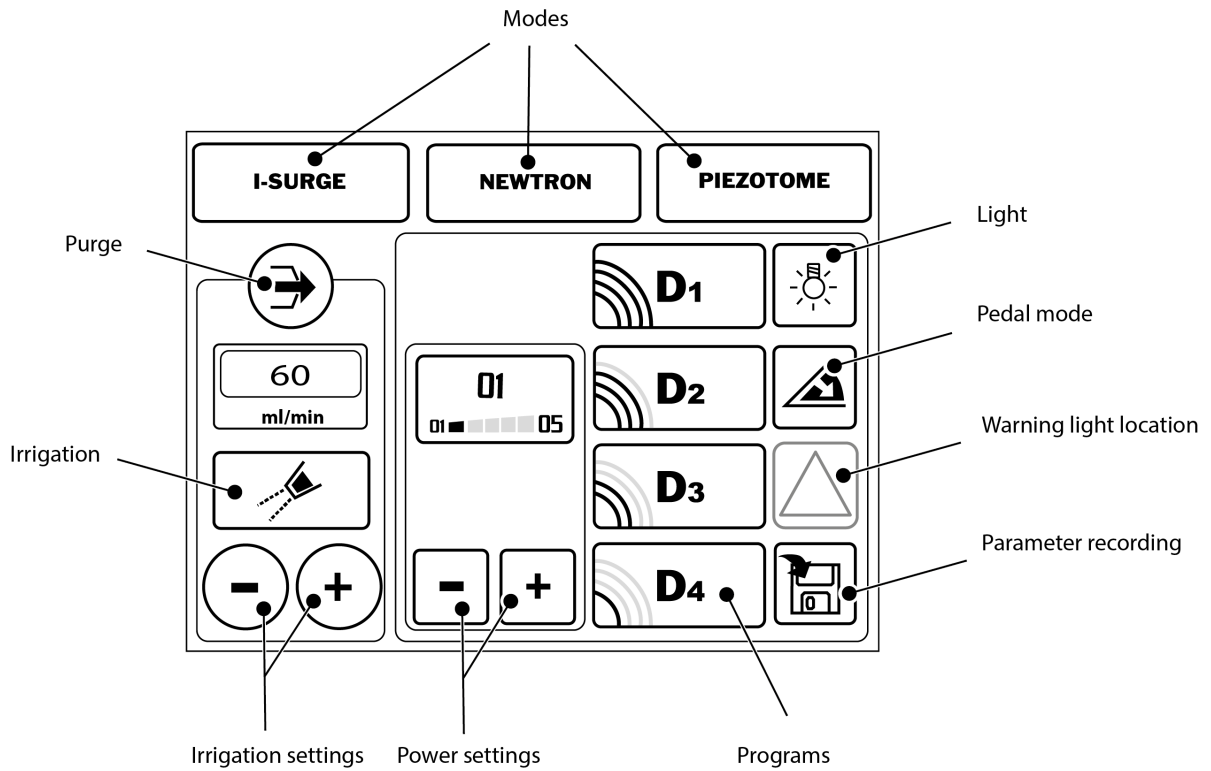

7.2.1.2 Newtron mode

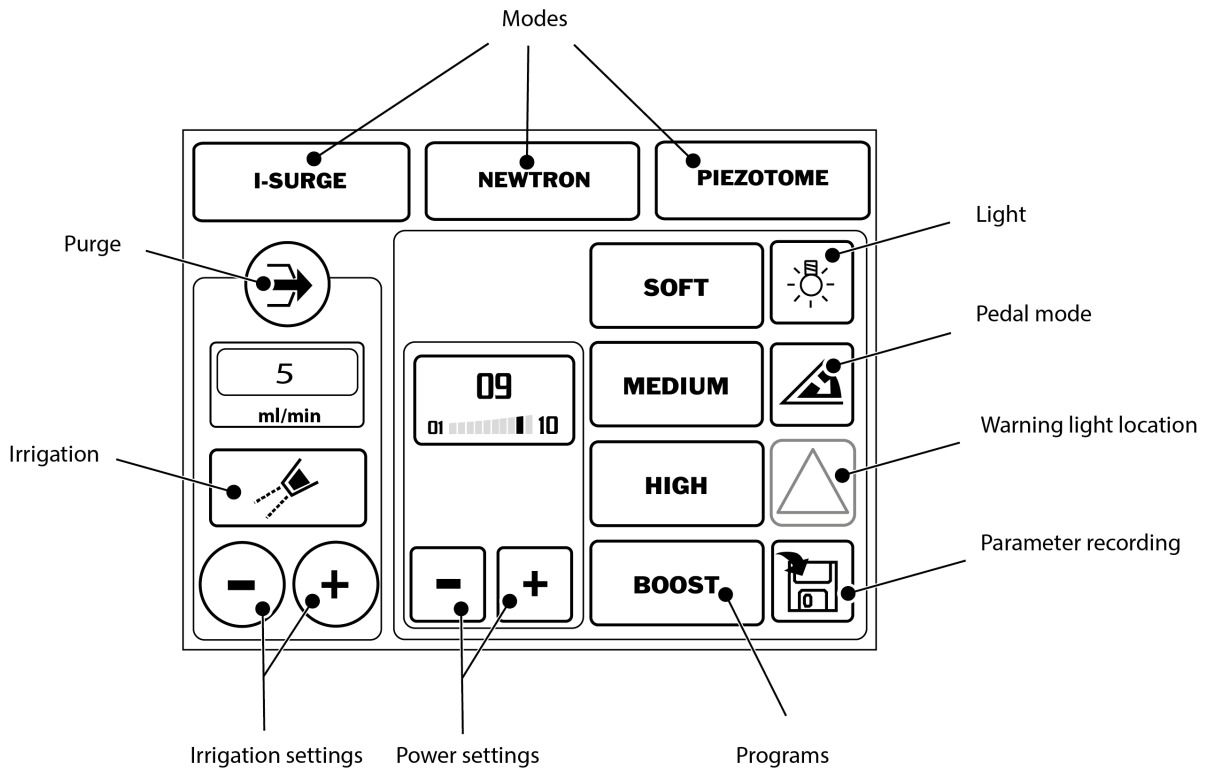



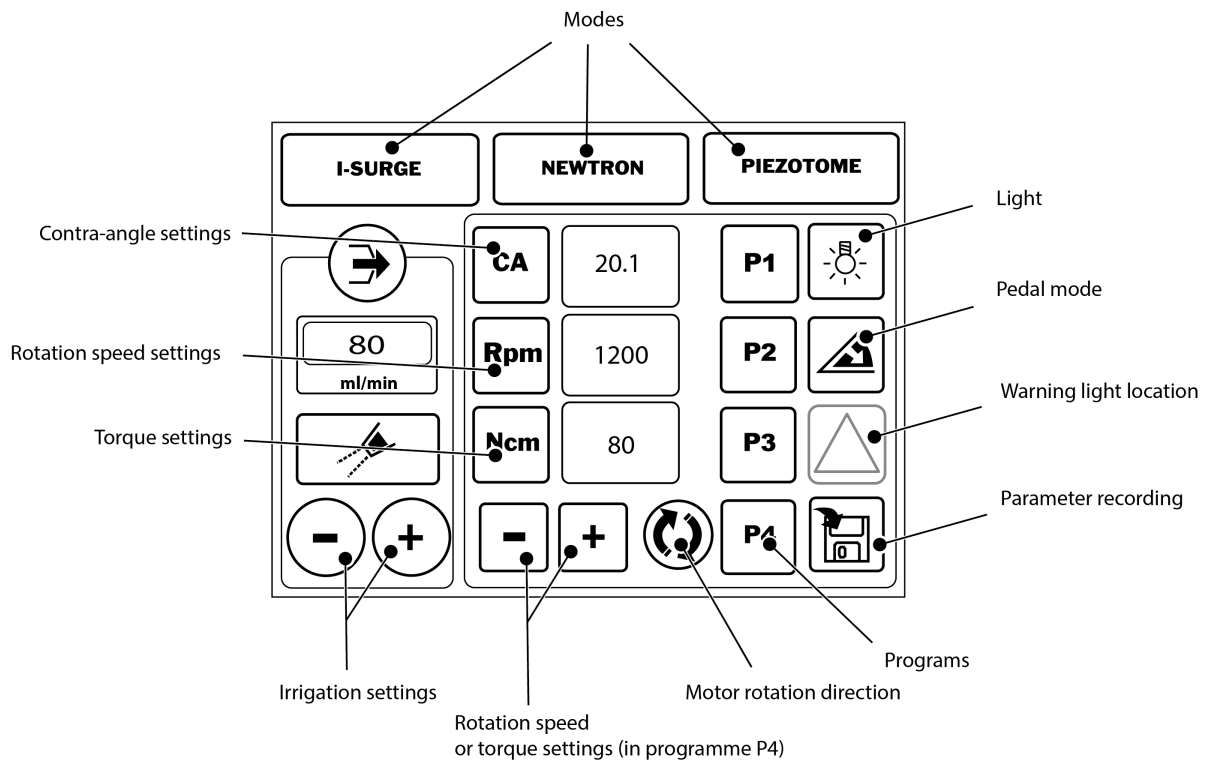



7.2.1.3 I-surge mode



7.2.2 Overview of the pedal

Pressing the footswitch automatically activates the handpiece ultrasounds, and the irrigation function if it is not deactivated.

	<p>In Newtron mode, press to cycle through programmes SOFT, MEDIUM, HIGH and BOOST. In Piezotome mode, press to cycle through programmes D1, D2, D3 and D4. In I-Surge mode, press to cycle through programmes P1, P2, P3 and P4.</p>
	<p>Press to enable or disable irrigation.</p>

	When the device is in I-Surge mode, press to activate the motor rotation.
	When the device is in Piezotome mode or Newtron mode, press to activate the ultrasound.
	Switch from motor to ultrasound and vice versa.
	Activate the purge.
	I-Surge mode. Activate motor reciprocation.

7.2.2.1 Piezotome mode

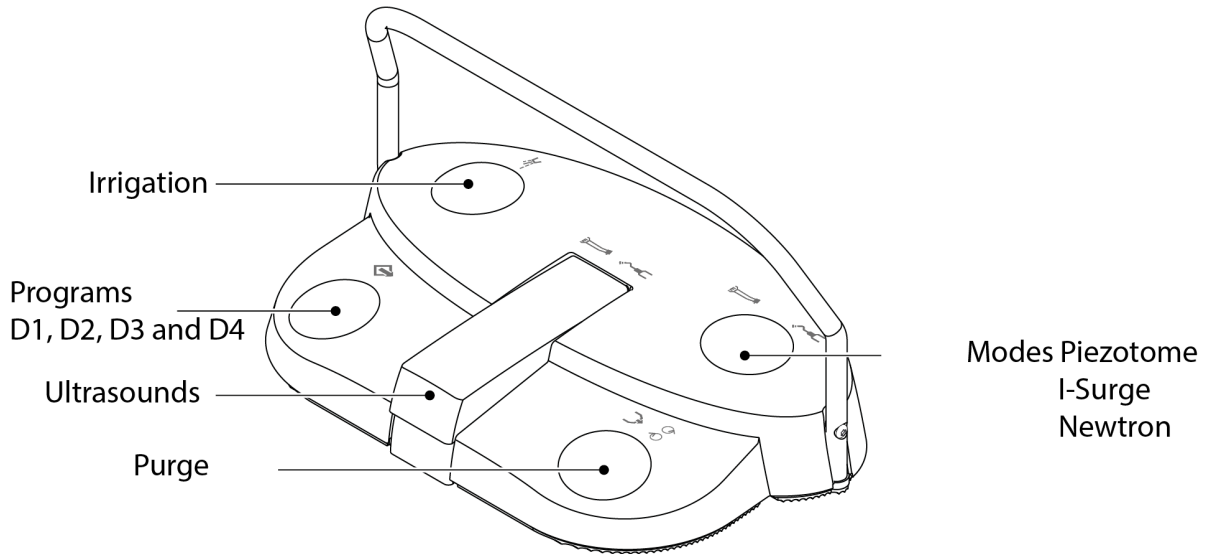

7.2.2.2 Newtron mode

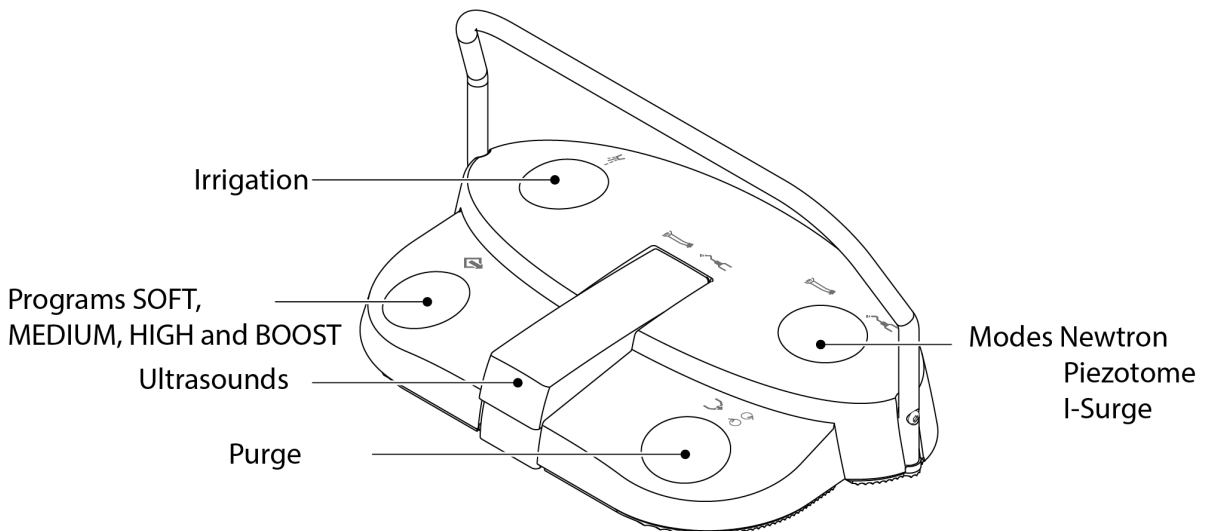

7.2.2.3 I-surge mode

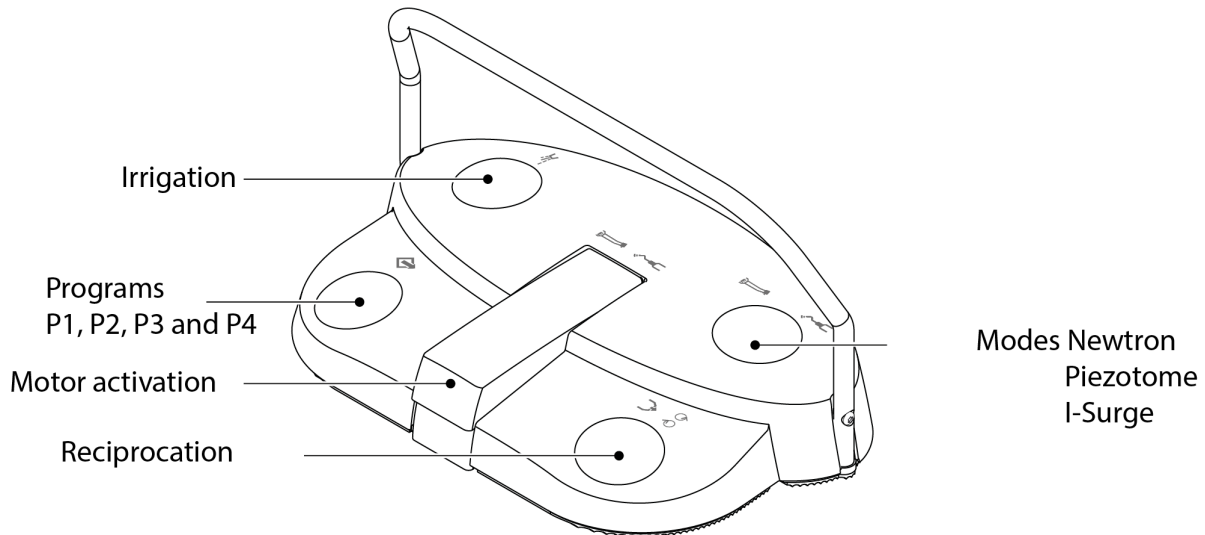

7.3 Accessories

7.3.1 Handpiece

The medical device must be used with a Piezotome LED handpiece for intraoral surgery. Refer to the user manual for the Piezotome LED I12815 handpieces as well as the protocol for cleaning, disinfecting and sterilizing Piezotome LED J12801 handpieces and cord for further information.

Refer to the user manual of the Cube LED J28821 handpiece, and to the protocol for cleaning, disinfecting and sterilising the J12801 handpieces and cord for further information.

The medical device must be used with a Newtron LED handpiece for dentistry. Refer to the user manual for the Newtron LED, [J12611] handpieces as well as the protocol for cleaning, disinfecting and sterilizing Newtron LED [J12911] handpieces for further information.

7.3.2 Handpiece support

The support holds the handpiece.

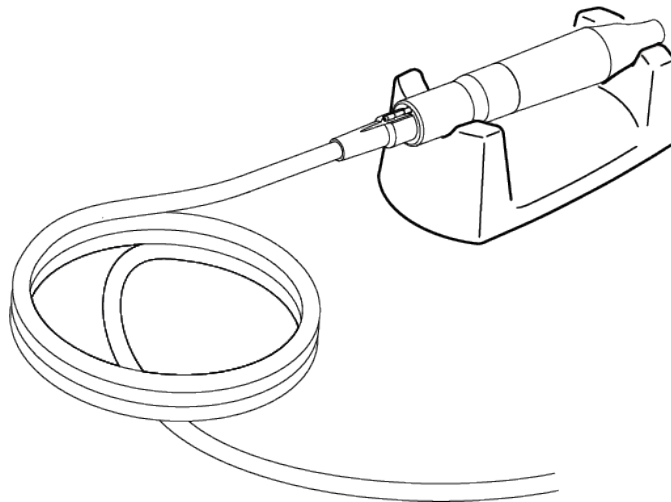

You have two supports: one for the I-Surge LED micromotor and another for the Piezotome LED and Newtron LED handpieces.

7.3.3 Handpiece cord

The cord ensures electrical connection between the medical device and the handpiece. The irrigation line which ensures the flow of irrigation between the irrigation bags and the handpiece are clipped onto the cord.

7.3.4 Irrigation lines

The autoclavable irrigation lines can be reused after cleaning, disinfection and sterilisation. After use, sterile irrigation lines should be discarded in a biomedical waste container.

Bottles or irrigation bags should not weigh more than one kilogram. A heavier container will make the medical device tip over.

The medical device is not designed to deliver medicinal substances.

The medical device may only be used with bags or bottles of saline solution or sterile water.

7.3.5 Motor

The I-Surge LED motor, via straight handpieces and contra-angles, turns rotary instruments.

7.4 Adjustments

7.4.1 I-Surge mode factory settings

Before any use of the I-Surge LED micromotor, you must refer to the setting recommendations specified by the contra-angle or handpiece manufacturer.

Ensure that you do not exceed the pre-programmed maximum torque value for the end of the tool, and do not go below 10% of this value.

I-Surge mode factory settings

Programme	Contra-angle coefficient	Speed at end of tool	Torque at end of tool	Irrigation	Function
P1	20:1	1200 rpm	80 N.cm	80 ml/min	Implant site marking
P2	20:1	800 rpm	80 N.cm	100 ml/min	Pilot drilling
P3	20:1	15 rpm	20 N.cm	100 ml/min	Boring/drilling
P4	20:1	30 rpm	20 N.cm	0	Screwing

7.4.2 Ultrasound power

The ultrasound power must be adjusted in accordance with the tip used and the required treatment. The operating power of the tips must be selected in compliance with the Acteon tips color coding system (CCS tips).

Each tip must be used in accordance with the settings defined in the ultrasonic generator irrigation and power settings table [J58000].

The ultrasound power must be adjusted in accordance with the tip used and the required treatment.

Each tip must be used in accordance with the settings defined in the power settings table for intraoral surgery ultrasonic generators [J58010].

7.4.2.1 Piezotome mode factory settings

Programme		Power	Irrigation
Very powerful	D1	3	60 ml/min
Powerful	D2	3	60 ml/min
Average power	D3	3	60 ml/min
Low power	D4	3	60 ml/min

Fine setting adjusts the power level for each programme between 1 and 5. The power value is a percentage of the maximum power at D1-4.

Programme	D1				
Fine setting level	1	2	3	4	5
Power value	82%	86 %	90 %	95 %	100 %
Frequency modulation	60 Hz				

Programme	D2				
Fine setting level	1	2	3	4	5
Power value	64 %	68 %	72 %	74 %	78 %
Frequency modulation	60 Hz				

Programme	D3				
Fine setting level	1	2	3	4	5
Power value	44 %	48 %	52 %	56 %	60 %
Frequency modulation	60 Hz				

Programme	D4				
Fine setting level	1	2	3	4	5
Power value	41 %	46 %	51 %	56 %	60 %
Frequency modulation	30 Hz				

7.4.2.2 Newtron mode factory settings

Each tip must be used in accordance with the settings defined in the ultrasonic generator irrigation and power settings table [J58000].

	Programme	Power	Irrigation
Green	Soft	P = 5	15 ml/min
Yellow	Medium	P = 5	15 ml/min
Blue	High	P = 5	15 ml/min
Orange	Boost	P = 5	15 ml/min

7.4.3 Irrigation

The medical device must be set to minimum power to adjust the irrigation flow rate. Press the footswitch until a spray appears.

Because work habits, feedback and professional training differ from one professional to another, the user must ensure that the irrigation flow is compatible with the procedure to be carried out to prevent burns to the clinical site.

Each tip must be used in accordance with the settings defined in the power settings table for intraoral surgery ultrasonic generators [J58010].

7.4.4 Adjusting the medical device volume

1. Switch on the medical device.

2. From the home screen, press  to open the menu.

3. Identify the pictogram indicating brightness .

4. Press  or  to adjust the screen brightness as required.

5. Press  to save the settings and start the medical device.

Or press  to exit the settings screen without saving the changes.

7.4.5 Adjusting the screen brightness

1. Switch on the medical device.

2. From the home screen, press  to open the menu.

3. Identify the pictogram indicating brightness .

4. Press  or  to adjust the screen brightness as required.

5. Press  to save the settings and start the medical device.

Or press  to exit the settings screen without saving the changes.

7.4.6 Adjusting the lighting timer

Press the footswitch to start the handpiece and release it to stop the handpiece. Once the handpiece has been stopped, it will continue to light up the treatment area for the period defined by the time delay.

1. Switch on the medical device.

2. From the home screen, press  to open the menu.

3. Identify the pictogram indicating the time delay .

4. Press  or  to adjust the screen time delay as required.

5. Press  to save the settings and start the medical device.

Or press  to exit the settings screen without saving the changes.

7.4.7 Recovering the medical device's factory settings

1. Switch on the medical device.

2. From the home screen, press  to open the menu.

3. Press  to recover all the factory settings.

4. Press  to save the settings and start the medical device.

Any customised contra-angle and any changes made to programmes will be deleted from the medical device's memory.

Or press  to exit the settings screen without saving the changes.

8 Disinfection and sterilising

The instructions relating to cleaning, disinfection and sterilisation protocols for accessories supplied by SATELEC, a company of Acteon group have been approved for each medical device and accessory. The applicable guides are listed in the chapter *Associated documentation page 5*.

They can be downloaded at the following address: www.satelec.com/documents.

Download



Instructions For Use

In all cases, the local regulations in force relating to the cleaning, disinfection and sterilisation protocols for accessories take precedence over the information provided by SATELEC, a company of Acteon group.

8.1 Clean and disinfect the medical device

The medical device's control unit must be cleaned and disinfected daily.

The medical device's control pedal must be cleaned and disinfected daily.

The handpiece and its cord must be cleaned, disinfected and sterilised after use.

- | Do not immerse the handpiece.

The autoclavable irrigation lines must be cleaned, disinfected and sterilised after each use.

The medical device must be in OFF or O stop position during cleaning and disinfecting procedures.

Refer to the instructions in the chapter *Cleaning the irrigation system page 43*.

Use alcohol disinfectant wipes.

Avoid using cleaning and disinfection products that contain flammable agents.

Otherwise, ensure that the product has completely evaporated or that there is no fuel left on the medical device and its accessories before switching it on.

- | Do not use an abrasive product to clean the medical device.

- | Never apply sprays directly to the medical device to clean it. Always spray the product onto a wipe, then clean the medical device.

The autoclavable irrigation lines must be cleaned, disinfected and sterilised after each use.

To prepare for cleaning, remove the various parts of the Implant Center 2 as shown here.

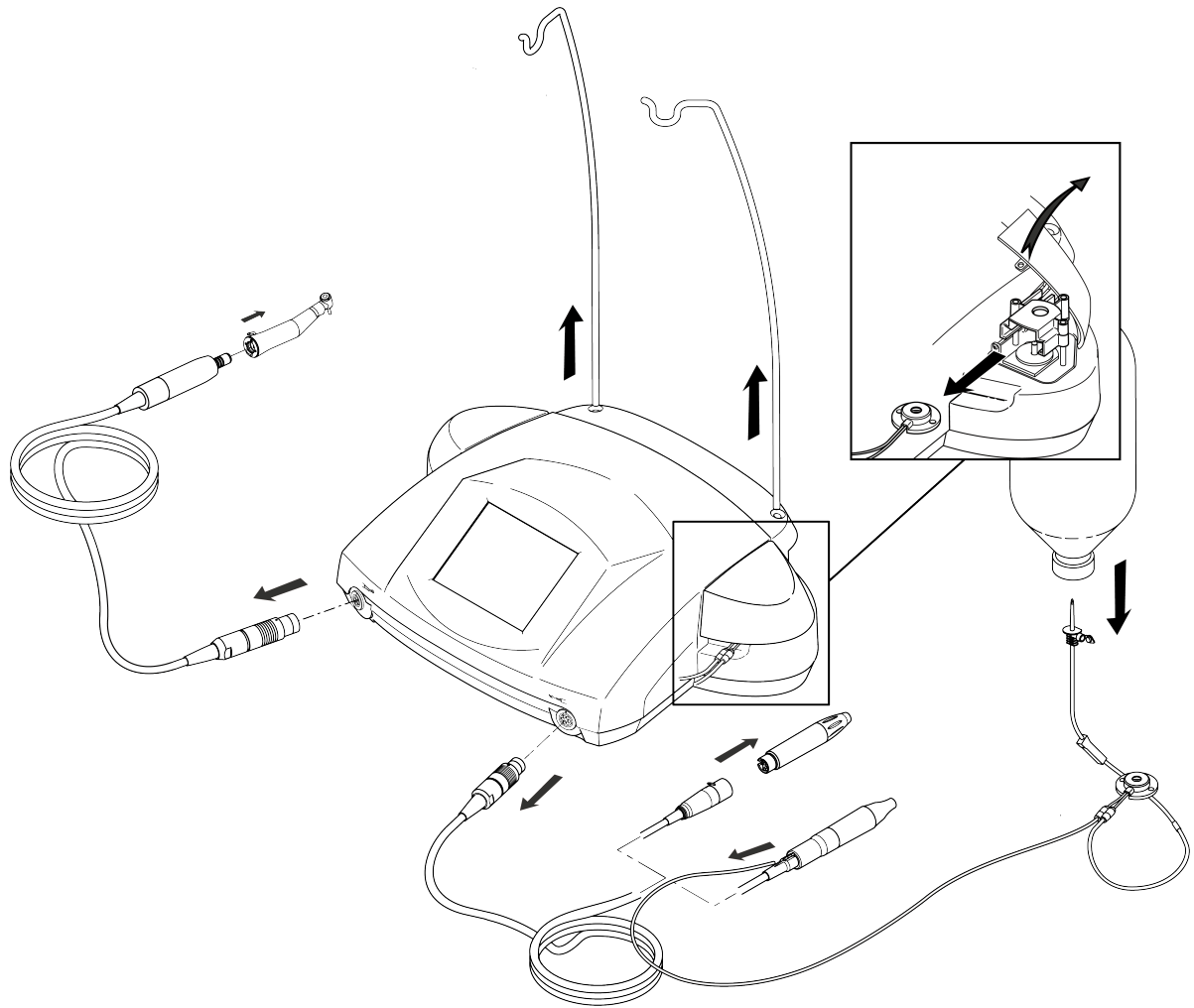

8.2 Cleaning, disinfecting and sterilising accessories

Refer to the cleaning, disinfection and sterilisation instructions for accessories listed in the chapter *Associated documentation page 5*.

9 Monitoring and routine maintenance

The only preventive maintenance the medical device requires is:

- Monitoring of accessories
- Routine cleaning, disinfection and sterilisation
- Cleaning

Check the cleanliness of the air inlets on the control unit to prevent any heating.

Check the condition of the handpiece-cord assembly and the cord connectors.

Check the condition of the handpiece rear seal, which must not be distended, torn or broken.

Check the cleanliness of the handpiece nosepieces. These must be clean, corrosion-free, and easy to install.

Before and after use, check the medical device and its accessories entirely for any problems. This is necessary to detect any electrical isolation fault or damage. If necessary, replace damaged parts.

9.1 Cleaning the irrigation system

This allows the autoclavable irrigation line to be cleaned prior to being disinfected, cleaned and sterilised.

When using irrigation solution bags to irrigate your medical device:

1. Disconnect the irrigation bag from the perforator of the irrigation line.
2. Dispose of the irrigation bag.
3. Dip the short end of the irrigation line in a recipient containing a hypochlorite solution diluted at less than 3%.



4. Press the Purge icon . The purge flow rate is 120 ml/min.
5. Operate the irrigation spray for two minutes to rinse the medical device's internal water system.
6. Refill the tank with demineralised or distilled water.
7. Rinse the irrigation system for two minutes.

When the irrigation system has been cleaned, perform the following operations:

1. Disconnect the handpiece and cord assembly and refer to the cleaning, disinfection and sterilisation protocols for the handpiece assembly [J12911] and [J12801], and the protocol for the micromotor [J28721].
2. Clean and disinfect the medical device as indicated in the chapter *Clean and disinfect the medical device page 41*.
3. Follow the instructions of protocols for cleaning, disinfecting and sterilising SATELEC, a company of Acteon group accessories [J81001] and [J02001].

9.2 Touch-sensitive screen messages

Use the touch-sensitive screen to configure the medical device. Depending on your actions, one or more of the following elements will be displayed.

9.2.1 Problem at start up



Symptom: the medical device beeps and displays the following pictogram:

Possible causes	Solutions
Internal error on start-up: there is no communication between the motherboard and screen	<ul style="list-style-type: none"> • Switch the medical device to "O" to turn it off. • Wait 5 seconds before switching it back on. • Switch the medical device to "I" and make sure that you do not touch any buttons while it is starting up.

9.2.2 Missing handpiece

Symptom: the medical device beeps when the user presses the footswitch and displays the following pictogram:



Possible causes	Solutions
Faulty connection between the handpiece cord and the medical device	<ul style="list-style-type: none"> • Connect the handpiece cord to the medical device. • Switch the medical device to "O" to turn it off. • Wait 5 seconds before switching it back on. • Switch the medical device to "I" and make sure that you do not touch any buttons while it is starting up.

9.2.3 I-Surge LED micromotor missing



Symptom: the medical device produces an audible signal and displays the following pictogram:

Possible causes	Solutions
Faulty connection between the I-Surge LED micromotor cord and the medical device	<ul style="list-style-type: none"> • Connect the I-Surge LED micromotor cord to the medical device. • Switch the medical device to "O" to turn it off. • Wait 5 seconds before switching it back on. • Switch the medical device to "I" and make sure that you do not touch any buttons while it is starting up.

9.2.4 Excessive motor temperature



Symptom: the medical device produces an audible signal and displays the following pictogram:

Causes	Solutions
The temperature of the I-Surge LED micromotor is too high. Only 25% of the motor torque is available so as to allow it to cool down.	<ul style="list-style-type: none"> • Allow the micromotor to cool down until the end of the programme.

9.3 Finding the software version

If you experience any problems with your medical device, SATELEC Customer Service may ask you to specify the software version installed on your medical device.

To view the software version, follow these instructions:

1. Switch on the medical device.



2. From the home screen, press  to open the menu.
3. Note down the value displayed at the bottom of the screen.



4. Press  to start the medical device.

9.4 Corrective Maintenance

In the event of faulty operation, the following corrective maintenance actions may be performed by the user.

9.4.1 Replacing the fuses

The medical device is protected by two fuses in the mains connector.

To replace the fuses, perform the following operations:

1. Stop the medical device (position O).
2. Disconnect the mains cord from the electrical network.
3. Disconnect the mains cord from the mains connector.
4. Insert the tip of a flathead screwdriver into the notch on top of the fuse holder to release it.
5. Remove the used fuses.

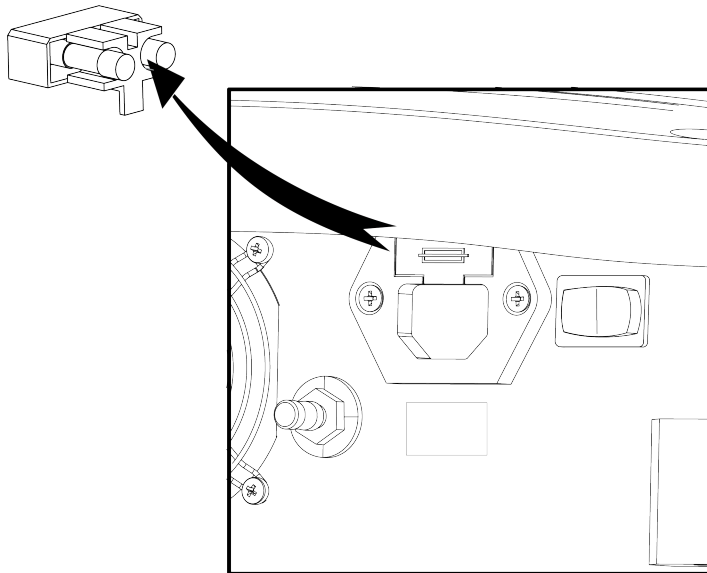

6. Replace the used fuses with fuses of the same type and same rating.
7. Place the fuse holder in its recess by pushing it until you hear a click that confirms it is in the correct position.
8. Connect the mains cord to the connector.
9. Connect the mains cord to the electrical network.

10 Identifying incorrect operation

In the event of incorrect operation, refer to the tables below to quickly identify and repair the non-complex parts of the medical device.

If the incorrect operation is not described in the tables below, please contact your supplier or the customer service team at SATELEC, a company of Acteon group.

Do not use the medical device if it appears to be damaged or faulty. Isolate the medical device and make sure that it cannot be used.

10.1 Precautions for use

When they are used, the handpieces heat up. It is a normal consequence of their proper operation.

Trust your feelings. If the handpiece becomes uncomfortably hot, stop the treatment, position the tip over a water drain and activate the purge for a few seconds to cool the handpiece.

10.2 Not working

Symptoms: the screen of the medical device is off and the medical device is not working.

Possible causes	Solutions
No electrical current	Contact your electrician
Mains switch in position O	Set the mains switch to position I
Faulty connection between the mains cord and the electrical wall socket	Connect the mains cord to the electrical wall socket
Faulty connection between the mains cord and the mains connector	Connect the mains cord to the mains connector
Mains fuses in the mains connector not working	Replace the mains fuses with fuses of the same type and rating
Internal fuse not working	Return to the Acteon Customer Service team
If the display is on, transmission failure	Turn off the medical device, wait a few seconds, then turn it back on Return to the Acteon Customer Service team

10.3 The micromotor is not working

Symptoms: micromotor not working

Possible causes	Solutions
Faulty micromotor	Check that the cordon connector is fully inserted into the device's motor connector. Return to the Acteon Customer Service team

Symptoms: the torque is not as expected

Possible causes	Solutions
Micromotor overheating and thermal protection triggered.	Allow the micromotor to cool down.
Incorrectly set torque	Adjust the torque in accordance with the accessory selected and best dental practice.
Unsuitable contra-angle	Change the contra-angle

Symptoms: the speed is not as expected

Possible causes	Solutions
Incorrectly set speed	Adjust the speed in accordance with the accessory selected and best dental practice.
Unsuitable contra-angle	Change the contra-angle

10.4 No spray

Symptom: There is no water spray at the tip.

Possible causes	Solutions
Blocked tip	Unblock the tip using an ultrasonic tank
Incorrect choice of tip	Check the tip
Inadequate amount of spray	Adjust the spray
Irrigation solution bag or bottle empty	Install a full container
Irrigation deactivated	Activate the irrigation flow
Irrigation line pinched, blocked or faulty	Install a new irrigation line.

10.5 The power is not as expected

Symptoms: the tip does not vibrate at the expected frequency, the treatment is not progressing as normal and is taking longer or is at a standstill.

Possible causes	Solutions
Worn or bent tip	Replace the tip
Incorrect use: incorrect angle of incidence or inadequate pressure	Refer to the user instructions available at www.acteongroup.com

10.6 Ultrasounds not working

Symptoms: the tip does not vibrate.

Possible causes	Solutions
The tip is incorrectly tightened	Fasten the tip using the wrench Replace your torque wrench once a year
Faulty connector contact	Clean the cord contacts
Handpiece cord wire(s) cut	Return to the Acteon Customer Service team to replace the cord
Cut handpiece cord	Return the handpiece and cord to the Acteon Customer Service team to have them replaced
Adjust the power	Please read the <i>Setting the power</i> chapter

10.7 Water leakage

Symptoms: There is a water leak along the irrigation line or at the handpiece and cord assembly.

Possible causes	Solutions
The handpiece irrigation inlet is damaged	Replace the handpiece and its cord. Return the handpiece and its cord to Satelec's Customer Service.
Pipe ruptured in the irrigation line cassette	Replace the irrigation line
Irrigation cassette not working	Replace the irrigation line

11 Technical specifications of the medical device

11.1 Identification

Manufacturer	SATELEC, a company of Acteon group
Name of the medical device	Implant Center 2

11.2 Generator

Supply voltage	100 - 230 VAC \pm 10 %
Power supply frequency	50 / 60 Hz
Power consumption	150 - 150 VA
Output frequency	Minimum 28 kHz
Power setting programmes	D1 - D4 in Piezotome mode
Power setting programmes	SOFT, MEDIUM, HIGH and BOOST in Newtron mode
Power and torque setting programmes	P1 to P5 in I-Surge mode
Type of leakage currents	BF
Operating mode	Intermittent: 10 minutes ON / 5 minutes OFF in Piezotome and Newtron modes
Operating mode	Intermittent: 20 seconds ON / 30 seconds OFF at 20 mNm in I-Surge mode
Electrical rating	I
Internal fuse not accessible to the user	1 fuse - F1: 5 mm x 20 mm - T10AL 250 V (AC)
Fuse (mains connector)	2 fuses - 5 mm x 20 mm - T2.5AL for 250 V (AC)
Width	472.9 mm
Height	149.5 mm
Height	471.1 mm with brackets
Depth	339.9 mm
Weight	5,000 g without accessories
Ingress protection rating	IPX0
Width screen	115 mm
Height screen	86 mm

11.3 Length of cords

Handpiece cord	2 500 mm +/- 50 mm
Control pedal cord	2 500 mm +/- 50 mm
Micromotor cord	2 500 mm +/- 50 mm

11.4 I-Surge LED micromotor

Length including nosepiece	90.6 mm
Length excluding nosepiece	69 mm
Diameter of the nosepiece	10 mm
max. Diameter	23.2 mm
Weight	115 g

Speed of rotation	100 to 40,000 rpm
Max. torque	60 mNm

11.5 Irrigation

Bottles or irrigation bags should not weigh more than one kilogram. A heavier container will make the medical device tip over.

Maximum volume of irrigation solution bags	1,000 ml each
Maximum weight of irrigation solution bags	1,000 g each
Nominal water output flow at the end of the handpiece Piezotome LED	10 ml/min to 120 ml/min
Handpiece irrigation adjustment setting Piezotome LED	10 ml/min
Nominal water output flow at the end of the I-Surge LED motor	10 ml/min to 120 ml/min
I-Surge LED motor irrigation adjustment setting	10 ml/min
Nominal water output flow at the end of the handpiece Newtron LED	10 ml/min to 40 ml/min
Handpiece irrigation adjustment setting Newtron LED	1 ml/min
Maximum water output flow at purge	120 ml/min

11.6 Footswitch

Width	311 mm
Height	181 mm
Depth	209 mm
Weight	3,500 g
Ingress protection rating	IPX1

11.7 Environmental characteristics

Ambient operating temperature	+10°C to +30°C
Operating RH	30% to 75 %
Atmospheric operating pressure	Between 800 hPa and 1060 hPa
Maximum operating altitude	Equal to or less than 2000 metres
Storage RH	10% to 100 %, including condensation
Atmospheric storage pressure	Between 500 hPa and 1060 hPa
Transportation temperature	0°C to +50°C
Transportation RH	10% to 100 %, including condensation
Atmospheric transportation pressure	Between 500 hPa and 1060 hPa

11.8 Environmental restrictions

Usage premises	Usable in all medical premises. The medical device must not be used in an operating theatre or outdoors.
Use in gas-filled atmosphere	The medical device is not designed for use in a type AP or APG gas-filled atmosphere or in the presence of anaesthetic gases.
Immersion	The console must not be immersed.
Immersion	The handpiece must not be immersed.

11.9 Main performance characteristics

Ultrasonic vibrations of the tip fitted to the end of the dental surgery ultrasonic handpiece.

Ultrasonic vibrations of the tip or file fitted to the end of the conventional dental ultrasonic handpiece.

- Vibration frequency ≥ 28 kHz.
- Modulation frequency

12 Regulations and standards

12.1 Applicable standards and regulations









This medical device complies with the essential requirements of European Directive 93/42/EEC. It was designed and manufactured in accordance with an EN ISO 13485-certified quality assurance system.















This equipment is designed and developed in compliance with the Electrical Safety standard IEC60601-1 in force.





12.2 Medical class of the device

Class of medical device: IIa according to 93/42/EEC directive



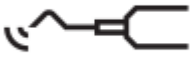

12.3 Symbols



Symbol	Meaning
	Footswitch
O	Switching off (OFF)
I	Switching on (ON)
 Protection Glasses Needed	Always wear safety goggles
	Always wear protective gloves
 Refer to Instruction Manual/Booklet	Refer to the supporting documentation
 Consult Instructions for Use	Consult the User Manual
 Electronic User Information	The accompanying documentation is available in electronic format
	Pressure limit
	Temperature limit
	Humidity limit

Symbol	Meaning
	Packaging unit
	Fragile, handle with care
	Store in a dry place
	Biohazard
	Sterilisation at 134°C in an autoclave
	Sterilisation at 132°C in an autoclave
	Washer-disinfector for thermal disinfection
	Type BF part in contact
<p>I</p>	Class 1
	Alternating current
	CE marking
	CE marking
<p>YYYY </p>	Year of manufacture
	Manufacturer
 Do not dispose of as household waste	Do not dispose of as household waste

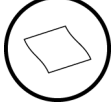
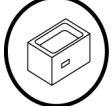
Symbol	Meaning
	Ultrasonic scale-remover
	Recycle your lamps and professional electrical equipment with Récylum
Rx Only	Under the United States Federal Law, this medical device must only be sold by or under the orders of a qualified doctor.
IPX1	IP: ingress protection ratings procured by a range X: no ingress of protection rating claim against the penetration of solids 1: protects against the vertical falls of drops of water
IPX0	IP: ingress protection ratings procured by a range X: no ingress of protection rating claim against the penetration of solids 0: no protection against the penetration of liquids
	Serial Number
	Packaging Number

12.4 Quick Start and Quick Clean symbols

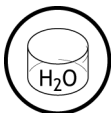
	Use a dipping tank for cleaning
	Use a soft brush for cleaning
	Use a lint-free cloth for cleaning
	Use an ultrasonic tank for cleaning.
	Use a swab for cleaning

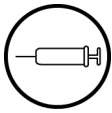
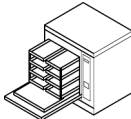
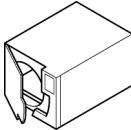
	Use deionised or osmosis-purified water for cleaning
	Use an alcohol disinfectant wipe for pre-disinfection and cleaning.
	Clean under running water
	Use a syringe for cleaning
	Use a washer-disinfector for cleaning and disinfection
	Use a pre-vacuum air autoclave for sterilisation

12.5 Manufacturer identification



SATELEC

A Company of the ACTEON Group

17, avenue Gustave Eiffel

BP 30216

33708 MERIGNAC cedex

France

Tel. +33 (0) 556.34.06.07

Fax. +33 (0) 556.34.92.92

E-mail: satelec@acteongroup.com

www.acteongroup.com



CE Marking

12.6 Branch addresses

AUSTRALIA/NEW ZEALAND

ACTEON AUSTRALIA/NEW ZEALAND

Suite 119, 30-40 Harcourt Parade

Rosebery NSW 2018

Australia

Tel. +612 9669 477 307

Fax. +612/96692204

info.au@acteongroup.com

RUSSIA

ACTEON RUSSIA

Gilyarovskogo str, 6b1, off 212

129090 MOSCOW

RUSSIA

Mob. +7 926 233 1695

Tel. +7 495 150 1323

info.ru@acteongroup.com

BRAZIL

MICRO IMAGEM INDUSTRIA COMERCIO IMPORTAÇÃO E EXPORTAÇÃO LTDA
CNPJ: 14.041.012/0001-79
Alameda Vênus, 233
Distrito Industrial
Indaiatuba – SP – CEP 13347-659
Brazil
Tel. +55 19 3936 809

CHINA

ACTEON CHINA
Office 401 - 12 Xinyuanxili Zhong Street -
Chaoyang District - BEIJING 100027 - CHINA
Tel. +86 10 646 570 11/2/3
Fax. +86 10 646 580 15
info.cn@acteongroup.com

GERMANY

ACTEON GERMANY GmbH
Klaus-Bungert-Str. 5
40468 Düsseldorf
GERMANY
Tel. +49 211 169800-0
Fax. +49 211 169800-48
info.de@acteongroup.com

INDIA

ACTEON INDIA
1202, PLOT NO. D-9
GOPAL HEIGHTS, NETAJI SUBASH PLACE
PITAMPURA, DELHI - 110034 - INDIA
Tel. +91 11 47 018 291 / 47 058 291 / 45 618 291
Fax. +91 79 2328 7480
info.in@acteongroup.com

ITALIA

ACTEON ITALIA
Via Roma 45
21057 OLGiate OLONA (VARESE)
ITALY
Tel. +39 0331 376 760
Fax. +39 0331 376 763
info.it@acteongroup.com

LATIN AMERICA

ACTEON LATINA AMERICA
Bogotá - COLOMBIA
Mobile: +57 312 377 8209
info.latam@acteongroup.com

SPAIN

ACTEON MEDICO-DENTAL IBERICA, S.A.U.
Avda Principal nº11 H
Poligono Industrial Can Clapers
08181 SENTMENAT (BARCELONA) - SPAIN
Tel. +34 93 715 45 20
Fax. +34 93 715 32 29
info.es@acteongroup.com

TAIWAN

ACTEON TAIWAN
11F., No.1, Songzhi Rd.
Xinyi Dist., Taipei City 11047
TAIWAN (R.O.C.)
+ 886 2 8729 2103
info.tw@acteongroup.com

THAILAND

ACTEON (THAILAND) LTD
23/45 Sorachai Building 16th floor - Sukumvit 63
Road, Klongton Nua - Wattana, BANGKOK 10110
- THAILAND
Tel. +66 2 714 3295
Fax. +66 2 714 3296
info.th@acteongroup.com

TURKEY

ACTEON TURKEY
Barbaros Mah. Dereboyu Cad.
Akzambak Sokak Uphill Towers
B Blok K14 D84 Atasehir
ISTANBUL 34746 - TURKEY
Mob. +90 532 481 20 57
Tel. +90 216 688 88 68
talha.gonca@acteongroup.com

U.K.

ACTEON UK
Phoenix Park– Eaton Socon, St Neots
CAMBS PE19 8EP - UK
Tel. +44 1480 477 307
Fax. +44 1480 477 381
info.uk@acteongroup.com

U.S.A. & Canada

ACTEON North America
124 Gaither Drive, Suite 140
Mount Laurel, NJ 08054 - USA
Tel. +1 856 222 9988
Fax. +1 856 222 4726
info.us@acteongroup.com

MIDDLE EAST
ACTEON MIDDLE EAST
247 Wasfi Al Tal str.
401 AMMAN - JORDAN
Tel. +962 6 553 4401
Fax. +962 6 553 7833
info.me@acteongroup.com

12.7 Disposal and recycling

As an item of Electrical and Electronic Equipment, the medical device must be disposed of via a specialist collection, removal, recycling or destruction channel. This applies in particular to the European market, with reference to Directive no. 2012/19/EC of July 2012.

When your medical device has reached the end of its service life, contact your nearest dental equipment dealer, or the Acteon head office or one of the company branches to find out how to proceed. The relevant contact details are given in the chapter *Branch addresses* page 56.



| The indication below applies to France only.

In compliance with the provisions of the French Environment Code relating to the disposal of electronic and electrical equipment waste or WEEE (Decree no. 2012-617 dated 2 May 2012), our Company fulfils its obligations to reclaim and dispose of its electrical and electronic equipment through the means established by the approved organisation Réylum, NOR approval: DEVP1427651A.

As a manufacturer, our Company is listed in the National Register of Producers kept by the ADEME (French Environment and Energy Management Agency). Professionals buying our products directly from the distribution chain are responsible for passing on this information about our established recycling methods to the end user.

In addition, the buyer agrees to take back our brand's devices at the end of their service life and to transfer them to one of the collection centres set up by Réylum for recycling (see list of collection centres on the site <http://www.reylum.com/>).

If necessary, Réylum can come and collect these devices from you free of charge once the quantity of devices has reached a certain level in the pallets-containers with which you are provided to store this waste.



An accessory that has reached the end of its service life must be disposed of in infectious clinical waste containers.

A medical device that has reached the end of its service life must be disposed of in infectious clinical waste containers.

13 Index

A

After installation 26
altitude 50
approved dealers 7

B

bone expansion 7

C

cleaned 17
cleaning and disinfecting the device 26, 43
cleaning the irrigation system 26
colour code 37
conservative and restorative dentistry 7
control pedal 13
control unit 27

D

damage 43
disinfected 17
disposal 59

E

earthing 28
electrical safety 53
electronic 5
electronic user instructions 5
end of day 26
endodontics 7
European directive 53

F

fault 43
first inclusion of CE marking 8
first use 26
Fuse 47
fuses 28, 44

G

gas-filled atmosphere 50

H

handpiece 5
Handpiece support 36

I

implantology 7
incorrect operation 47
inlets 28, 43

K

key 5

M

mains connector 11, 28, 44
Mains power 11
Manufacturer 49
medical class 53
Medicinal substances 37
membrane detachment 7

N

non-use 26

O

one kilogram 37, 50
osteoplasty 7
osteotomy 7

P

periodontics 7
pressure 50
procedure 37
prophylaxis 7

R

reciprocation 35
recycling 59
Récylum 59
repair 7
repairer 7
restoration 7

S

Saline solution 37
slope of five degrees 13
spray 38, 47
Sterile water 37
sterilised 17
switch 28, 47
syndesmotomy 7

T

temperature 50
tip 5, 7, 47-48

U

ultrasonic vibrations 7
update 8
User Manual 5

V

Vibration frequency 51

W

water leakage 48



User Manual | Implant Center 2 | J27171EN | V1 | (10) | 04/2022 | NO20EN010A

SATELEC S.A.S. | A Company of ACTEON Group
17 av. Gustave Eiffel | BP30216 | 33708 MERIGNAC cedex | FRANCE
Tel. +33(0)556340607 | Fax. +33(0)556349292
E-mail : satelec@acteongroup.com | www.acteongroup.com

